

Power Solution Specialist



INVT Power System

Power Solution Specialist

INVT Power System (Shenzhen) Co.,LTD
Tel: (86-755)26782480
Fax: (86-755)26782664
E-mail: upssales@invt.com.cn
Http: www.invt-power.com
Add: Building A, INVT Guangming Technology Building, Songbai Road,
Matian, Guangming District, Shenzhen, China



INVT Copyright
Information may be subject to change without notice during product improving

202412(V2.9)



Stock code : 002334

INVT POWER SYSTEM (SHENZHEN) CO.,LTD



About us

INVT Power, a key high-tech company, subsidiary company of INVT Group (Stock code: 002334), is the leading total power solution provider in China.

Over the past years, we have been dedicated to providing high quality products and service to global customers. So far, we have gained more than 1300 patents and our customers and partners are from more than 80 countries and areas in government, finance, internet, communication, traffic, electric and industry. With the high quality and top-class services, we are adding values to all our customers.

We aim at offering fast customized solutions to our customers and continuous innovation for more competitive products and services.

You are warmly welcome to be our distributor and partner. Meanwhile, we can provide OEM and ODM production and service for clients all around the world.



Shenzhen Industrial park



Suzhou Industrial park



Fuyong production base



How we make difference

Research and Innovation

- 12 Research centers
- 13% sales revenue for research and innovation
- IPD integrated products development system
- TUV witness Qualification LAB in Power Industry
- 1300 Intellectual Property Right, 30% more than average level

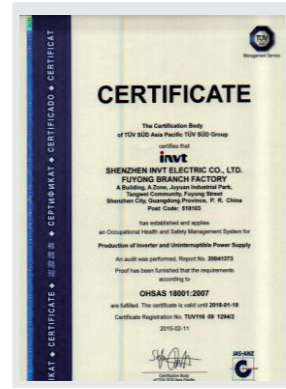
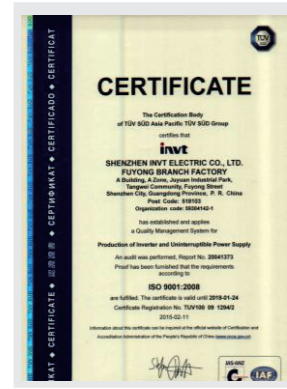
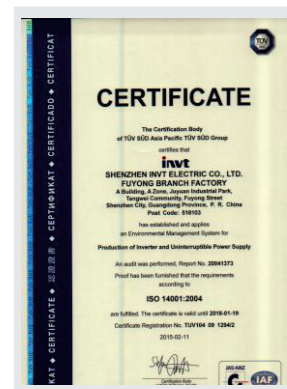

• TUV Witness Qualification LAB

• UL Witness Qualifications LAB



Safety Lab



Climate Environment Lab



Performance Test Lab



Components Test Lab



Mechanical Environment Lab



Dust-proof and Water-proof Lab



EMC Lab



Equipment Development Lab



UPS R&D Lab



Production Management System

INVT Power ensures high quality products and fast response to our customers by applying advanced Supply Chain Management System based on Quality Control Management, Delivery Management, Service and Strategic Control System.

INVT applies Standardized Operational System. We standardize the operational process for production, ensuring effectiveness, quality and cost control.

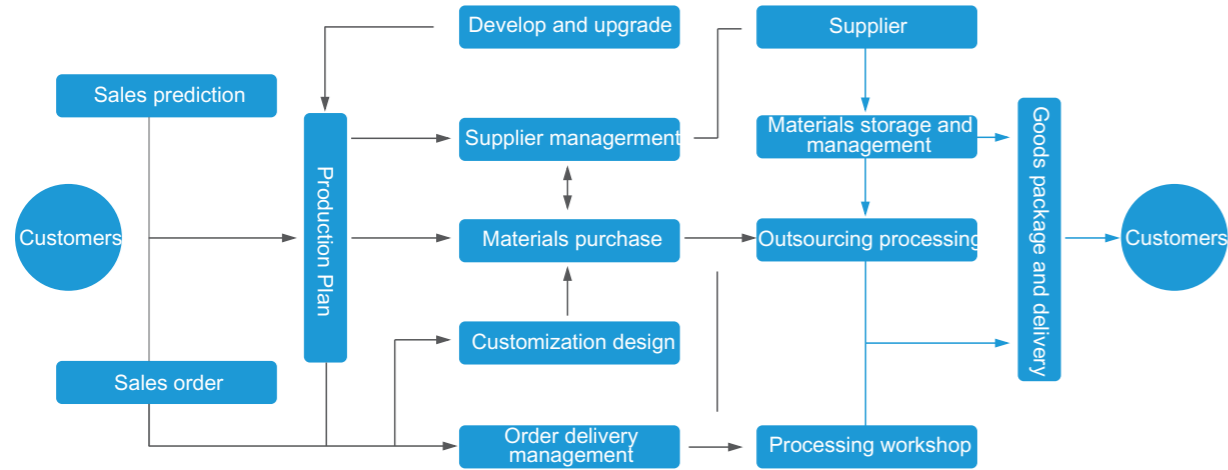

High Efficiency Supply

INVT Power adopts the most advanced international production mode as ISCM, JIT and LEAN, ensuring high efficiency and fast supply.

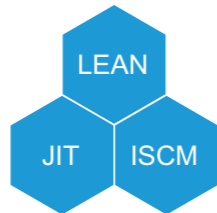

Honor

A state-level Hi-tech enterprise
National outstanding energy-saving enterprise
Famous brand in Guangdong province

Top 100 independent innovation enterprise
Top 10 China customer satisfaction brand
Procurement finalists brand by central governments

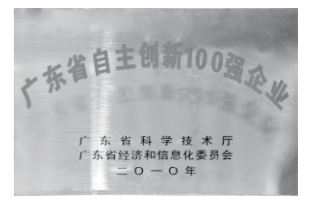
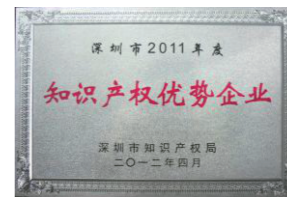

Quality Assurance

We apply comprehensive quality assurance to ensure the quality control of the whole product life circle



- R&D and production management system certificated by TUV and ISO9001:2008
- Environmental Management System: ISO14001: 2004
- Occupational Health and Safety Management OHSAS 18001:2007



Contents

RM Series Modular Online UPS (25-600kVA) -----	01
RM Series Rack-Mounted Modular Online UPS (25-300kVA) -----	07
RM Series Rack-Mounted Modular Online UPS (10-90kVA) -----	09
RM Series Modular Online UPS (20-200kVA)-----	11
RM Series In-built Battery Modular Online UPS (20-60kVA) -----	13
RM Series Modular Online UPS (40-600kVA)-----	15
RM Series Modular Online UPS (5-20kVA) -----	17
RM Series Modular Online UPS (60-600kVA)-----	19
RM Series Modular Online UPS (100-600kVA)-----	21
HT33 Series Tower Online UPS (60-500kVA) -----	23
HTD33 Series Tower Online UPS (120-200kVA)-----	25
HT33 Series Tower Online UPS (10-40kVA) -----	27
HT33-TX Series Tower Online UPS (10-40kVA) -----	29
HR33 Series Rack Online UPS (10-40kVA)-----	31
HT31 Series Tower Online UPS (10-40kVA)-----	33
HR31 Series Tower Online UPS (15-20kVA) -----	35
HT11 Series Tower Online UPS (6-20kVA)-----	37
HT11 Series Tower Online UPS (1-3kVA)-----	39
HTC11 Series Tower Online UPS (1-3kVA)-----	41
HR11 Series Rack Online UPS (1-10kVA) -----	43
HRC11 Series Rack Online UPS (1-3kVA) -----	45
Rack battery cabinet -----	47
Smart Remote Monitor -----	48
Smart Charging Module -----	49
Energy Absorbing Unit -----	50
24A External Charger -----	51
Load Bus Synchronization -----	52
Battery Cabinet -----	53
MF Series Sealed Lead Acid Battery -----	54

RM Series Modular Online UPS 25-600kVA (380V/400V/415V)

The RM series modular UPS provides the most compact footprint of less than 2m² with maximum capacity of 900kVA. With the best reliability and high performance, it has been leading the domestic market for years.

RM series is considered to be the best power protection solution for large data centers, as well as for sensitive electronics.



Independent LCD for Each Power Module

Each power module has an independent LCD, giving users a direct overview of status data and alarms in real time.



Friendly Interface

Providing graphical and text based information of alarms, status data, instructions so that users can have more friendly and safer operation.

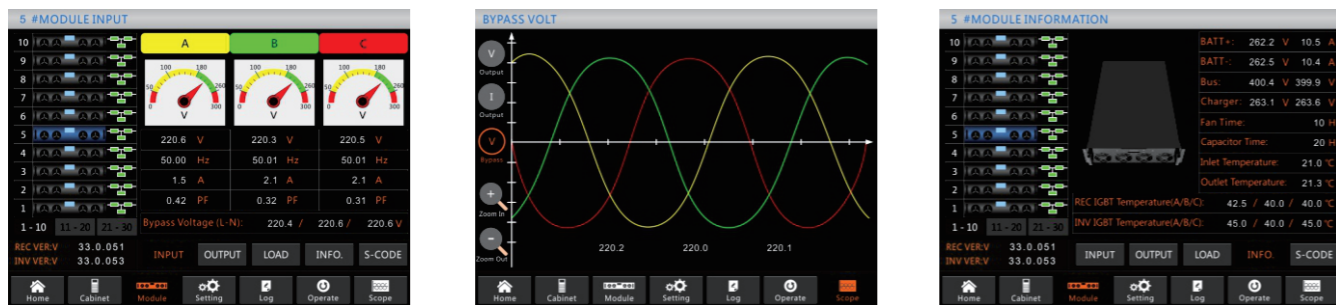

Isolated Air Flow

The dedicated and redundant hot-swappable power modules take the most unique structure design. In this design, the PCB boards and heat-sinkers are in two completely different layers, which allows the UPS run in dusty environments, significantly improving its stability and environmental adaptability.

- Cooling air flows in the lower layer, keeping the upper PCB free of dust
- One air flow channel ensures fans redundancy, even one fan fails, power module can run normally

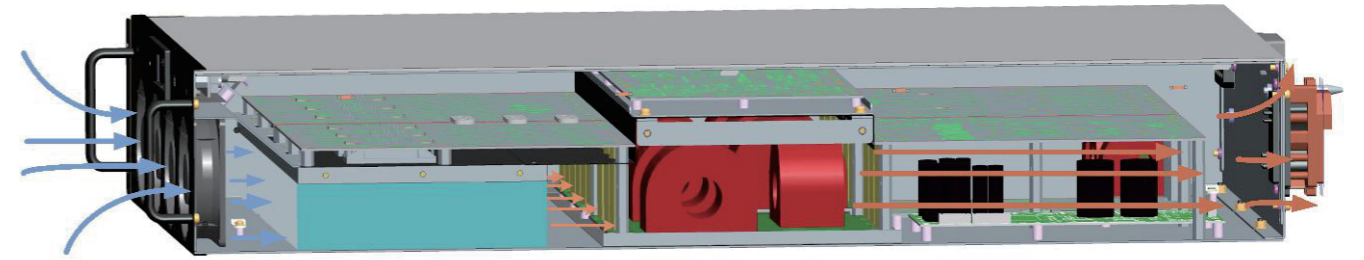

Unique Design for High Reliability

Instead of discrete IGBT and SCR components, RM series UPS uses modular IGBT and SCR in Rectifier and Inverter, bringing in extremely high reliability.

- All components in one module, less fault points, higher reliability
- All components integrated as one modular design, smaller disparity
- Less space needed, UPS with compact design and higher power design
- Integrated inner thermal sensors display IGBT inner temperature directly

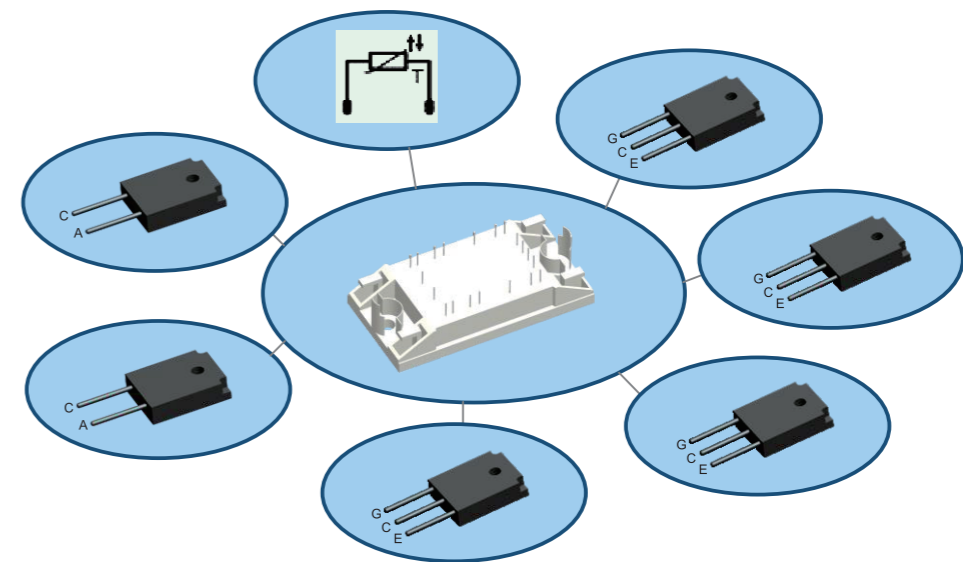

High Density ,Modular, Scalable

- High power density, footprint for 300kVA is 0.66m², power density 409kW/m², saving valuable data center space
- Scalable from 30kVA to 900kVA, max 30 power modules in parallel



Three units in parallel

- Inherently N+X redundant
- Hot swappable power module and bypass & monitoring module
- Additional charging module, extra charging current 50A×N for long time back up application



Bypass & Monitoring module



Power module



Comprehensive Monitoring Management

In each power module, information of critical components is monitored and displayed in real time, giving customers a view of inner status of the system and providing reminder information for maintenance.

- Maintenance reminder, running time of capacitors and fans displayed and recorded
- Comprehensive temperature monitoring for thermal abnormal detection
- Intelligent battery charger for long battery life

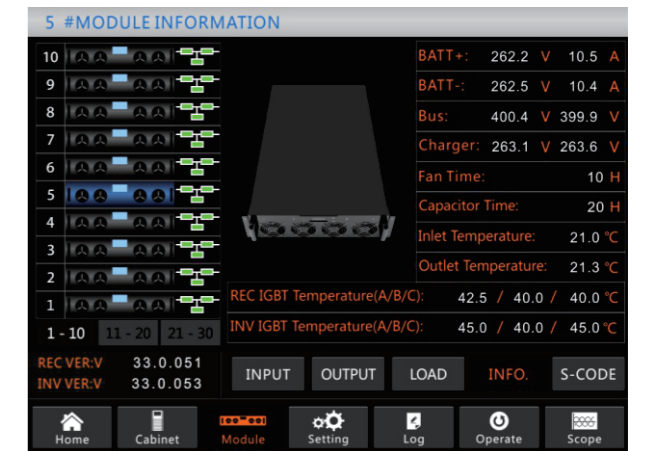

Critical Waveform Recording

UPS can record and save the data of the main parameters automatically when faults happen for further analysis.

- Can record data information and present as waveform for further analysis
- Can easily spot the causes of the failures, avoid future similar faults

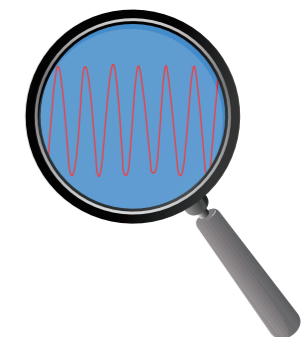
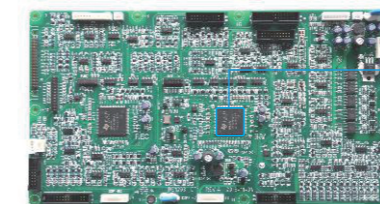

Smart Sleep

Smart Sleep function can intelligently make some power modules go to sleep when load is relatively low, improving the efficiency of the remaining power modules and saving customers on power and cooling costs.

- Improving efficiency, reducing power and cooling costs
- Easy setting with just two steps. Customers can select sleep mode and rotation period
- Power modules working in rotation, prolong the life time

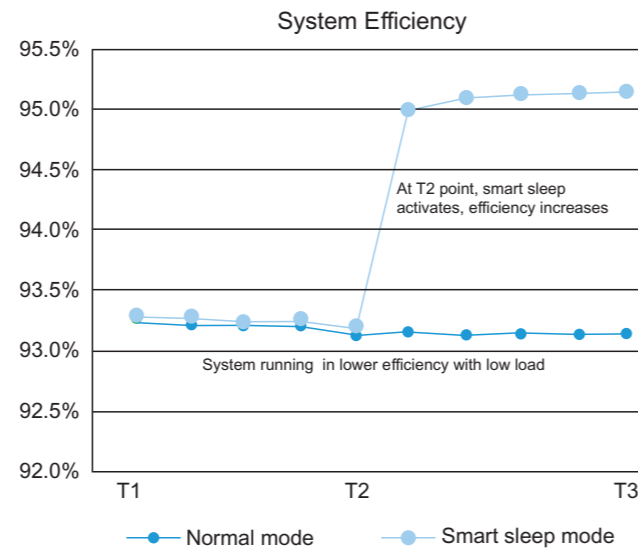

Self-aging

Self-aging is an advanced function applied in all three phase UPS. Self-aging function can test UPS under different load situation without real load, saving more than 90% of energy.

- Simulate different load conditions without connecting to any real load, saving 90% of energy
- On-site setting is supported, easy for factory testing

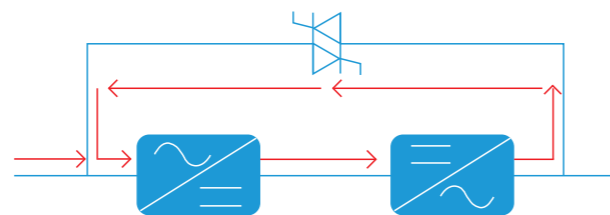

Programmable Dry Contacts

Programmable dry contacts are available in all RM and HT33 series UPS. Customers can easily expand or modify the definition of each port.

- Abundant options with three inputs and four outputs, all programmable
- Easy setting, just pull the drop-down menu and set
- Compatible with all the RM and HT33

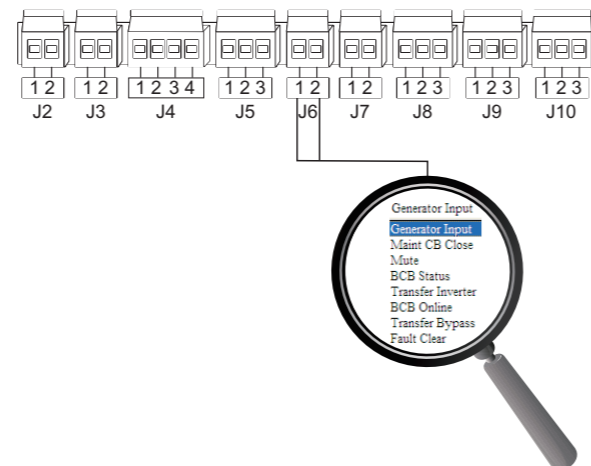

Specification

MODEL	RM600/30X	RM300/30X	RM180/30X	RM500/25X	RM250/25X	RM150/25X		
System Capacity	600kVA	300kVA	180kVA	500kVA	250kVA	150kVA		
Power Module Capacity	30kVA/30kW			25kVA/25kW				
Input	Dual Input	Optional						
	Phase	3 Phase+Neutral+Ground, 380V/400V/415V (line-line)						
	Input Voltage Range	304~478Vac (line-line), full load; 228V~304Vac (line-line), load decreases linearly according to the min. phase voltage						
	Rate Frequency	50/60Hz						
	Input Frequency Range	40Hz ~ 70Hz						
	Input PF	>0.99						
Bypass	Input THDi	<3% (100% Linear load)						
	Rate Voltage	380/400/415Vac (line-line)						
	Rate Frequency	50/60Hz						
	Input Voltage Range	Settable, -40% ~ +25%						
	Bypass Frequency Range	Settable, ±1Hz, ±3Hz, ±5Hz						
	Bypass Overload	110% long term operation; 125% for 5 mins; 150% for 1 min						
Output	Rate Voltage	380/400/415Vac (line-line)						
	Voltage Regulation	1% for balance load; 1.5% for unbalance load						
	Rate Frequency	50/60Hz						
	Frequency Precision	0.1%						
	Output PF	1						
	Output THDu	<1% , Linear load; <5.5%, Non-linear load						
	Crest Factor	3:1						
	Inverter Overload	110% for 1 hour; 125% for 10 mins; 150% for 1 min; >150% for 200 ms						
	Battery	Voltage	±240Vdc					
		Battery Number	40pcs (Settable: even number from 32 to 44)					
Voltage Precision		±1%						
Charge Power		up to 20% * Output active power						
Battery Cold Start		Standard						
System	Efficiency	AC Mode	95.0%					
		ECO Mode	99.0%					
		Battery Mode	95.0%					
	Display	10.4" color touch screen LCD + LED + keyboard						
	IP Class	IP 20						
	Interface	RS232, RS485, Programmable Dry Contact, USB						
	Option	SNMP Card, Parallel kit, SPD, LBS, Dust filter, Expansion dry contact card						
	Temperature	Operation: 0 ~ 40 °C Storge: -40 ~ 70 °C						
	Relative Humidity	0 ~ 95% Non-condensing						
	Altitude	<1000m. Within 1000m to 2000m, 1% power derating for every 100m rise						
	Noise (1 meter)	72dB@100%load	65dB@100%load	72dB@100%load	65dB@100%load			
		65dB@45%load	62dB@45%load	65dB@45%load	62dB@45%load			
	Applicable Standards	Safety: IEC/EN 62040-1 EMC: IEC/EN 62040-2 Performance: IEC/EN 62040-3						
	Physical	Weight (kg)	Cabinet	660	242	178	660	242
Power module			32.3			32.3		
Dimension W*D*H(mm)		Cabinet	2000*1050*2000	600*1100*2000	600*1100*1600	2000*1050*2000	600*1100*2000	600*1100*1600
	Power module	460*790*134						

RM Series Rack-Mounted Modular Online UPS 25-300kVA (380V/400V/415V)

The RM Series Rack Mounted Modular UPS is scalable, hot-swappable, online double conversion. The power capacity is from 25 to 300kVA/kW, which is the ideal choice for modern data center. With the latest IGBT three-level and full DSP control technology, the new RM series delivers the best combination of reliability and flexibility.



Application

IDC(Internet Data Center), network servers and workstation, control system, communication system, office, PC etc

Features

- High Power Density
25kVA power module in 2U height, saving a great amount of space, easy for capacity expansion
- Rack Modular Design
Module design, compatible with 19" standard rack cabinet, convenient to be integrated with servers
- Battery Cold Start
UPS can be powered on from the battery without utility
- Friendly Interface
Touch LCD display with abundant information

Specification

MODEL	RM150/25C	RM200/25C	RM300/25C		
System Capacity	150kVA	200kVA	300kVA		
Power Module Capacity	25kVA/25kW				
Input	Dual Input	Optional	Standard		
	Phase	3 Phase+Neutral+Ground, 380V/400V/415V(line-line)			
	Input Voltage Range	304~478Vac (line-line), full load; 228V~304Vac (line-line), load decreases linearly according to the min. phase voltage			
	Rate Frequency	50/60Hz			
	Input Frequency Range	40Hz ~ 70Hz			
	Input PF	>0.99			
Bypass	Input THDi	<3% (100% Linear load)			
	Rate Voltage	380/400/415Vac (line-line)			
	Rate Frequency	50/60Hz			
	Input Voltage Range	Settable, -40% ~ +25%			
	Bypass Frequency Range	Settable, ±1Hz, ±3Hz, ±5Hz			
Output	Bypass Overload	110% long term operation; 125% for 5 mins; 150% for 1 min; >150% for 1s			
	Rate Voltage	380/400/415Vac (line-line)			
	Voltage Regulation	±1 (0~100% linear load)			
	Rate Frequency	50/60Hz			
	Frequency Precision	0.1%			
	Output PF	1			
	Output THDu	<1% , Linear load; <6%, Non-linear load			
	Crest Factor	3:1			
Battery	Inverter Overload	110% for 1 hour; 125% for 10 mins; 150% for 1 min; >150% for 200 ms			
	Voltage	±240Vdc			
	Battery Number	40pcs (Settable: even number from 32 to 44)			
	Voltage Precision	±1%			
	Charge Power	up to 20% * Output active power			
System	Battery Cold Start	Standard			
	Efficiency	AC Mode	96.0%		
		ECO Mode	98.0%		
		Battery Mode	95.5%		
	Display	10.4"(300kVA) or 7.0"(150-200kVA) color touch screen LCD + LED + Keyboard			
	IP Class	IP 20			
	Interface	RS232, RS485, Programmable Dry Contact			
	Option	PDU for RM150/25C, SNMP Card, Parallel kit, SPD, LBS			
	Temperature	Operation: 0 ~ 40 °C Storge: -40 ~ 70 °C			
	Relative Humidity	0 ~ 95% Non-condensing			
	Altitude	<1000m. Within 1000m to 2000m, 1% power derating for every 100m rise			
	Noise (1 meter)	65dB @ 100% load, 62dB @ 45% load			
Applicable Standards	Safety: IEC/EN 62040-1 EMC: IEC/EN 62040-2 Performance: IEC/EN 62040-3				
Physical	Weight (kg)	Cabinet	116	200	295
		Power module	18		
	Dimension W*D*H(mm)	Cabinet	482*916*931	482*916*1550	650*1100*2000
		Power module	436*677*85		

RM Series Modular Online UPS 20-200kVA (380V/400V/415V)

RM series is modular online UPS for sensitive equipments. The single cabinet power rating covers from 20kVA to 200kVA. With the latest IGBT three-level and full DSP control technology, the RM series delivers the best of combination of reliability, hot-swappable and flexibility.



Features

Modular design

Up to 20 power modules in parallel online hot-swappable N+X redundancy

Independent charger

Independent charger for each module and intelligently control the whole charging process, prolong the life time of the battery

Battery cold start

UPS can be powered on from the battery without utility

Easy connection access

Top and bottom cable entry connection are supported, more convenient for site installation

Modular design with transformer

Modular UPS up to 60kVA with in-built isolation transformer, meeting different requirement for customers

High power density

200kVA with footprints of about 0.5m², saving valuable data center space

Integrated IGBT design

Integrated IGBT in one module, less failure points with higher performance and reliability

Friendly interface

Touch LCD display with abundant information

Independent air channel

Cooling air runs in isolated channel, keeping PCB free of dust



Specification

MODEL	RM200/20	RM120/20	RM060/20	
System Capacity	200kVA	120kVA	60kVA	
Power Module Capacity	20kVA/18kW			
Input	Dual Input	Optional		
	Phase	3 Phase+Neutral+Ground, 380V/400V/415V (line-line)		
	Input Voltage Range	304~478Vac (line-line), full load; 228V~304Vac (line-line), load decreases linearly according to the min. phase voltage		
	Rate Frequency	50/60Hz		
	Input Frequency Range	40Hz ~ 70Hz		
	Input PF	>0.99		
Bypass	Input THDi	<3% (100% Linear load)		
	Rate Voltage	380/400/415Vac (line-line)		
	Rate Frequency	50/60Hz		
	Input Voltage Range	Settable, -40% ~ +25%		
	Bypass Frequency Range	Settable, ±1Hz, ±3Hz, ±5Hz		
Output	Bypass Overload	125% long term operation; 130% for 1 hour; 150% for 6 mins; 1000% for 100 ms		
	Rate Voltage	380/400/415Vac (line-line)		
	Voltage Regulation	1% for balance load; 1.5% for unbalance load		
	Rate Frequency	50/60Hz		
	Frequency Precision	0.1%		
	Output PF	0.9		
	Output THDu	<1% , Linear load; <5.5%, Non-linear load		
	Crest Factor	3:1		
	Inverter Overload	110% for 1 hour; 125% for 10 mins; 150% for 1 min; >150% for 200 ms		
	Battery	Voltage	±240Vdc	
Battery Number		40pcs (Settable: even number from 32 to 44)		
Voltage Precision		±1%		
Charge Power		up to 20% * Output active power		
Battery Cold Start		Standard		
System	Efficiency	AC Mode	95.0%	
		ECO Mode	99.0%	
		Battery Mode	95.0%	
	Display	5.7" touch screen LCD + LED + keyboard		
	IP Class	IP 20		
	Interface	RS232, RS485, Programmable Dry Contact		
	Option	SNMP Card, Parallel kit, SPD, LBS, Dust filter		
	Temperature	Operation: 0 ~ 40 °C Storge: -40 ~ 70 °C		
	Relative Humidity	0 ~ 95% Non-condensing		
	Altitude	<1000m. Within 1000m to 2000m, 1% power derating for every 100m rise		
	Noise (1 meter)	55dB @ 50% load		
Applicable Standards	Safety: IEC/EN 62040-1 EMC: IEC/EN 62040-2 Performance: IEC/EN 62040-3			
Physical	Weight (kg)	Cabinet	180	
		Power module	22	
	Dimension W*D*H(mm)	Cabinet	600*900*2000	600*900*1600
		Power module	440*590*134	

RM Series Rack-Mounted Modular Online UPS 10-90kVA (380V/400V/415V)

The rack modular, scalable, hot-swappable, online double conversion UPS is ranging from 10 to 90kVA, with its flexible configuration of 3/3, 3/1 and 1/1, compact structure, is the ideal choice for small and medium data center.



Features

Rack modular design

Modular design, compatible with 19" standard rack cabinet, convenient to be integrated with servers

High power density

10/15kVA power module in 2U height, saving great amount of space, easy for capacity expansion

Integrated solution for data center

UPS can be integrated with battery cabinet, PDU and external maintenance bypass, offering excellent choice for data center

Intelligent charging management

The system intelligently control the whole process of the charging and discharging, effectively improving the life time of the battery

Flexible configuration

The system based on 10kVA power module can be configured to 3/3, 3/1 and 1/1 without derating

Friendly interface

7" touch color LCD with graphic display, more information displayed and easier for customer to operate

Smart sleep function

System can intelligently shutdown some power modules to increase total load rate, achieving higher efficiency

Self-aging mode

Energy internal circle technology, system can run with full load, saving more than 90% energy

Specification

MODEL	RM060/10X	RM040/10X	RM030/10X	RM020/10X	RM090/15X	RM045/15X	RM030/15X		
System Capacity	60kVA	40kVA	30kVA	20kVA	90kVA	45kVA	30kVA		
Power Module Capacity	10kVA/10kW				15kVA/15kW				
Input	Dual Input	Standard							
	Phase	3 Phase+Neutral+Ground, 380V/400V/415V(line-line)							
	Input Voltage Range	304~478Vac (line-line), full load; 228V~304Vac (line-line), load decreases linearly according to the min. phase voltage							
	Rate Frequency	50/60Hz							
	Input Frequency Range	40Hz ~ 70Hz							
	Input PF	>0.99							
	Input THDi	<4% (100% Linear load)							
Bypass	Rate Voltage	380/400/415Vac (line-line)							
	Rate Frequency	50/60Hz							
	Input Voltage Range	Settable, -40% ~ +25%							
	Bypass Frequency Range	Settable, ±1Hz, ±3Hz, ±5Hz							
Bypass Overload	125% long term operation; 130% for 10mins; 150% for 1 min; >150% for 300ms				110% long term operation; 130% for 5mins; 150% for 1 min; >150% for 300ms				
Output	Rate Voltage	380/400/415Vac (line-line)							
	Voltage Regulation	1% for balance load; 1.5% for unbalance load							
	Rate Frequency	50/60Hz							
	Frequency Precision	0.1%							
	Output PF	1							
	Output THDu	<1%, Linear load; <5.5%, Non-linear load							
	Crest Factor	3:1							
	Inverter Overload	110% for 1 hour; 125% for 10 mins; 150% for 1 min; >150% for 200 ms							
Battery	Voltage	±240Vdc							
	Battery Number	40pcs (Settable: even number from 32 to 44)							
	Voltage Precision	±1%							
	Charge Power	up to 20% * Output active power							
	Battery Cold Start	Optional							
System	Efficiency	AC Mode	95.0%						
		ECO Mode	98.0%						
		Battery Mode	94.5%						
	Display	7.0" color touch screen LCD + LED + keyboard							
	IP Class	IP 20							
	Interface	RS232, RS485, Programmable Dry Contact							
	Option	SNMP Card, Parallel kit, SPD, Power module with battery cold start function							
	Temperature	Operation: 0 ~ 40 °C Storge: -40 ~ 70 °C							
	Relative Humidity	0 ~ 95% Non-condensing							
	Altitude	<1000m. Within 1000m to 2000m, 1% power derating for every 100m rise							
	Noise (1 meter)	56dB @ 50% load							
	Applicable Standards	Safety: IEC/EN 62040-1 EMC: IEC/EN 62040-2 Performance: IEC/EN 62040-3							
	Physical	Weight (kg)	Cabinet	70	51	55	42	70	55
Power module			15.3				15.5		
Dimension W*D*H(mm)		Cabinet	485*751*1033	485*697*575	485*751*575	485*697*398	485*751*1033	485*751*575	485*697*398
	Power module	436*590*85							

RM Series In-built Battery Modular Online UPS 20-60kVA (380V/400V/415V)

RM060/20B series is modular online UPS with hot-swappable battery. The single cabinet power rating covers from 20kVA to 60kVA which delivers the best of combination of reliability, hot-swappable and flexibility.

With intelligent battery protection and management technology, RM060/20B realizes a compact total power solution which is easy for installation, maintenance and power expansion.



Features

- Modular design with swappable battery package
- Monitoring system for battery
- Integrated IGBT module with improved performance and reduced size
- Easy for installation and maintenance
- Easy for power expansion and backup time expansion
- Intelligent protection technology for safe and reliable hot swappable battery package of the system
- Smart charging management system, intelligently control the whole process of the charging and discharging, effectively improving the life time of the battery
- Battery cold start
- Friendly human machine interface with touch screen



10pcs 7 or 9 Ah batteries

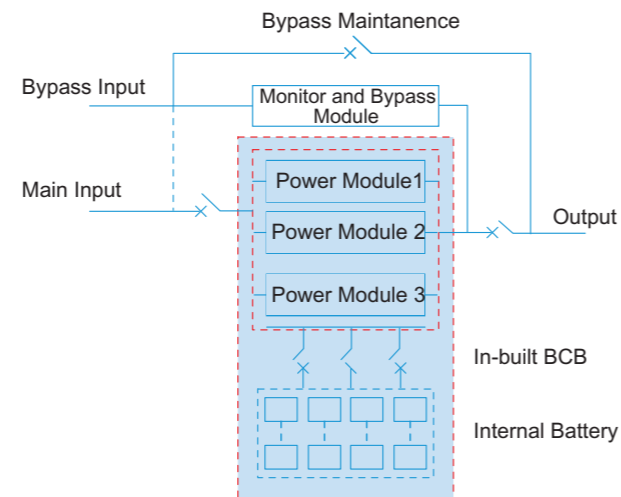

Specification

MODEL	RM060/20B		
System Capacity	60kVA		
Power Module Capacity	20kVA/18kW		
Input	Dual Input	Optional	
	Phase	3 Phase+Neutral+Ground, 380V/400V/415V(line-line)	
	Input Voltage Range	304~478Vac (line-line), full load; 228V~304Vac (line-line), load decreases linearly according to the min. phase voltage	
	Rate Frequency	50/60Hz	
	Input Frequency Range	40Hz ~ 70Hz	
	Input PF	>0.99	
Bypass	Input THDi	<3% (100% Linear load)	
	Rate Voltage	380/400/415Vac (line-line)	
	Rate Frequency	50/60Hz	
	Input Voltage Range	Settable, -40% ~ +25%	
	Bypass Frequency Range	Settable, ±1Hz, ±3Hz, ±5Hz	
Bypass Overload	125% long term operation; 130% for 1 hour; 150% for 6 mins; 1000% for 100 ms		
Output	Rate Voltage	380/400/415Vac (line-line)	
	Voltage Regulation	1% for balance load; 1.5% for unbalance load	
	Rate Frequency	50/60Hz	
	Frequency Precision	0.1%	
	Output PF	0.9	
	Output THDu	<1% , Linear load; <5.5%, Non-linear load	
	Crest Factor	3:1	
	Inverter Overload	110% for 1 hour; 125% for 10 mins; 150% for 1 min; >150% for 200 ms	
Battery	Voltage	±240Vdc	
	Battery Number	40pcs (Settable: even number from 32 to 44)	
	Voltage Precision	±1%	
	Charge Power	up to 20% * Output active power	
	Battery Cold Start	Standard	
Efficiency	AC Mode	95.0%	
	ECO Mode	99.0%	
	Battery Mode	95.0%	
System	Display	5.7" touch screen LCD + LED + keyboard	
	IP Class	IP 20	
	Interface	RS232, RS485, Programmable Dry Contact	
	Option	SNMP Card, Parallel kit, SPD, LBS, Dust filter	
	Temperature	Operation: 0 ~ 40 °C Storge: -40 ~ 70 °C	
	Relative Humidity	0 ~ 95% Non-condensing	
	Altitude	<1000m. Within 1000m to 2000m, 1% power derating for every 100m rise	
	Noise (1 meter)	55dB @ 50% load	
	Applicable Standards	Safety: IEC/EN 62040-1 EMC: IEC/EN 62040-2 Performance: IEC/EN 62040-3	
	Weight (kg)	Cabinet: 205kg Power module: 22kg Battery package: 10kg (without battery)	
Physical	Dimension W*D*H(mm)	Cabinet	600*1020*2000
		Power module	440*590*134
		Battery package	120*824*177

RM Series Modular Online UPS 40-600kVA (380V/400V/415V)

The RM series modular, online UPS ranging from 40kVA to 600kVA is designed to protect any critical load for medium and large data center achieving maximum availability. The RM series features the latest technology of 3-level technology and PFC input control, which guarantees high efficiency of 96% and ultra-reliability. Its compact design ensures power density of 600kVA in one cabinet, 3 units can be paralleled for capacity or redundancy up to 1500kVA, making it an excellent choice for medium and large facilities.



Features

Compact design

600kVA in one cabinet, footprint less than 1.45m², saving valuable room space

High power density

50kVA power module in 4U height, easy for capacity expansion

High efficiency

Advanced 3-level technology guarantees high efficiency operating in double conversion mode up to 96%

Intelligent charging management

The system intelligently control the whole process of the charging and discharging, effectively improve the life time of the battery

High scalability

The system can be configured from 40kVA to 600kVA in one single cabinet, 3 units in parallel for a capacity up to 1500kVA

Friendly HMI

10.4" touch color LCD with graphic display, independent LCD for each power module

Smart sleep function

System can intelligently shutdown some power modules to increase total load rate, achieving higher efficiency

Multi communication interface

Provide RS232, RS485, USB, SNMP, AS400 and programmable dry contacts

Specification

MODEL	RM600/50X	RM500/50X	RM400/50X	RM300/50X	RM200/50X	RM100/50X	RM240/40X	RM160/40X	RM080/40X		
System Capacity	600kVA	500kVA	400kVA	300kVA	200kVA	100kVA	240kVA	160kVA	80kVA		
Power Module Capacity	50kVA/50kW						40kVA/40kW				
Input	Dual Input	Standard									
	Phase	3 Phases + Neutral + Ground, 380/400/415VAC (line-line)									
	Input Voltage Range	304~478Vac (Line-Line),full load 228V~304Vac (line-line),load decrease linearly according to the min. phase voltage									
	Rated Frequency	50/60Hz									
	Input Frequency Range	40Hz ~ 70Hz									
	Input PF	>0.99									
	Input THDi	<3% (100% Linear Load)									
Bypass	Rate Voltage	380/400/415VAC (Line-Line)									
	Rate Frequency	50/60Hz									
	Input Voltage Range	Settable, -40% ~ +25%									
	Input Frequency Range	Settable, ±1Hz, ±3Hz, ±5Hz									
Bypass Overload	110% Long term operation 110%~125% last for more than 5 min 125%~150% last for more than 1 min			125%, long time <130%, for 10 mins <150%, for 1 min			110% long term 125% for 5 mins 150% for 1 min		125%, long time 130%, for 10 minutes 150%, for 1 min		
Output	Rated Inverter Voltage	380/400/415VAC (Line-Line)									
	Voltage Regulation	1% for balance load; 1.5% for unbalance load									
	Rate Frequency	50/60Hz									
	Frequency Precision	0.1%									
	Output PF	1									
	Output THDu	<1% linear load; <5.5% non-linear load									
	Crest Factor	3:1									
Inverter Overload	<110% for 1 hour; 125% for 10 mins; 150% for 1 min; >150% for 200 ms										
Battery	Battery Rate Voltage	±240VDC									
	Battery Number	40pcs (settable: even number from 32 to 44)									
	Voltage Precision	1%									
	Charger Power	up to 20% *Output active power									
	Battery Cold Start	Standard			Optional			Standard		Optional	
System	Efficiency	AC Mode: 96% ECO Mode: 99% Battery Mode: 96%									
	Display	10.4" (240-600kVA) or 7" (80-200kVA) touch screen LCD + LED+ Keyboard									
	IP Class	IP20									
	Interface	RS232, RS485, USB, Programmable dry contact									
	Option	SNMP, Parallel kit, SPD, Dust Filter, LBS									
	Temperature	Operation: 0 ~ 40 °C Storage: -40 ~ 70 °C									
	Relative Humidity	0 ~ 95% Non condensing									
	Altitude	<1000m, Load derated 1% per 100m From 1000 ~ 2000m									
	Noise (1 meter)	72dB @ 100% load, 69dB @ 45% load									
Applicable Standard	Safety: IEC/EN 62040-1 EMC: IEC/EN 62040-2 Performance: IEC/EN 62040-3										
Physical	Weight (kg)	Cabinet	1040	900	700	490	350	210	490	350	210
		Power module	45						44		
	Dimension W*D*H (mm)	Cabinet	1300*1100*2000	1050*1000*2000	650*1095	650*960	600*980	650*1095	650*960	600*980	600*980
		Power module	510*700*178						510*700*178		

RM Series Modular Online UPS 5-20kVA (220V/230V/240V)

RM3120/05D series is modular online UPS with hot-swappable battery. The single cabinet power is ranging from 5kVA to 20kVA, with its flexible configuration of 3/1 and 1/1, compact structure is the ideal choice for small data center, as well as for sensitive electronics, convenient to be integrated with server. With its high power factor and excellent overload capability, and the improvement of the efficiency of power utilization, it ensures the system operate steadily.



Application

All kinds of small and medium data center, network servers, control system, precision instruments and intelligent equipments.

Features

- High efficiency, more than 94.5%
- Rack modular design, compatible with 19" standard rack cabinet, convenient to be integrated with server
- Easy for power expansion and backup time expansion
- Intelligent protection and monitoring technology for safe and reliable battery package of the system
- Modular design with swappable power module and battery
- Flexible configuration, based on 5kVA can be configured to 3/1 and 1/1 without derating
- Friendly interface with 7" touch color LCD with graphic display, more information displayed and easier to operate
- Complete solution for small data room center

Specification

MODEL		RM3120/05DS		
System Capacity		20kVA		
Power Module Capacity		5kVA/5kW		
Input	Phase	3Phase+Neutral+Ground, 380V/400V/415V (line to line)		
	Input Voltage Range	277~478Vac (line-line),full load; 147~277Vac (line-line) load decreases linearly from 100%~50% according to the min. phase voltage		
	Rate Frequency	50/60Hz		
	Inout Frequency Range	40~70Hz		
	Input PF	>0.99		
Bypass	Input THDi	<5%(100%Linear load)		
	Rate Voltage	220V/230V/240V (line-neutral)		
	Rate Frequency	50/60Hz		
	Input Voltage Range	settable, default -20% ~ +15%; upper limit: +25%; lower limit: -40%		
	Bypass Frequency Range	settable,±1Hz, ±3Hz, ±5Hz		
Output	Rate Voltage	220V/230V/240V (line-neutral)		
	Voltage Regulation	±2%		
	Rate Frequency	50/60Hz±0.01%		
	Output PF	1		
	Output THDu	<1% linear load, <5% non-linear load		
	Inverter Overload	Normal	<110% for 1 hour; 110%~130% for 10 mins; 130%~150% for 1 mins; >150% for 200 ms	
		Battery	<110% for 10 mins; 110%~125% for 1 min; 125%~130% for 10 s; >130% for 200 ms	
	Battery	Voltage	144VDC (12pcs, settable 12 to14pcs)	
		Charge Power	0~1.8A settable(each module) 0-10A (charger module)	
		Voltage Precision	1%	
System	Efficiency	AC Mode	>94.5%	
		Eco Mode	>98%	
		Battery Mode	>90%	
	Display	LCD+LED, 7" touch color screen and keyboard		
	IP Class	IP20		
	Interface	Standard: RS232, RS485, USB		
	Option	SNMP card, Dry contacts card, AS400 card, SPD, dust filter, LBS		
	Temperature	Operation: 0-40°C Storage: -40~70°C		
	Relative Humidity	0-95% Non-condensing		
	Altitude	<1000m, Load derated 1% per 100m From 1000~2000m		
Noise(dB) (1 meter)	55dB @100% load			
Physical	Weight(kg)	UPS		
		Battery		
	Dimension (W*D*H)(mm)	Cabinet	66.5kg	67.3kg
		Module	7.5kg	17.8kg
Dimension (W*D*H)(mm)	Cabinet	443*695*928		
	Module	200*431*84.5	200*516*84.5	

RM Series Modular Online UPS 60-600kVA (380V/400V/415V)

RM600/60D series are modular online UPS with brand-new topology, a bidirectional DC-DC converter circuit, which greatly improve the system performance and guarantees high efficiency of 97%. Its compact design ensures the power density, achieving this 600kW system's occupation only an area of 0.9m². RM series is considered to be an excellent power supply solution for large data centers and facilities.



Features

Staggered and combined power supply

The utility and battery supply power to the load together and the compensation ratio is automatically calculated

Friendly HMI

Ultra-large 10" color touch LCD display for IoT application, storage of the history log up to 2000

Compact design

600kVA in one cabinet, footprint less than 0.88m², saving great space of data center

Multi communication interface

Provide CAN, RS485, USB, SNMP, AS400 and programmable dry contacts

High power density

60kVA power module in 2U height, easy for capacity expansion

High scalability

The system can be configured from 60kVA to 1.8MW, max 30 power modules 3 cabinets in parallel.

Intelligent charging management

The system intelligently control the whole process of the charging and discharging, double side DC-DC topology, support charging power reaching 30%

Smart sleep function

System can intelligently shutdown some power modules to increase total load rate, achieving higher efficiency

Specification

Model	RM 600/60D		
System Capacity	600kVA		
Power Module Capacity	60kVA/kW		
Input	Dual Input	Standard	
	Phase	3Phase+Neutral+Ground, 380/400/415VAC (line-line)	
	Rate Frequency	50/60Hz	
	Input Voltage Range	323~478Vac (line-line), full load 323V~138Vac (line-line), load decrease linearly from 100% to 30% according to the min. phase voltage	
	Input Frequency Range	40Hz ~ 70Hz	
	Inpput PF	>0.99	
Bypass	Input THDi	<3% (100% Linear load)	
	Rate Voltage	380/400/415VAC (line-line)	
	Rate Frequency	50/60Hz	
	Input Voltage Range	Settable, default -20%~+15% Up limit: +10%, +15%, +20%, +25% Down limit: -10%, -15%, -20%, -30%, -40%	
Bypass	Bypass Frequency Range	Settable, ±1Hz, ±3Hz, ±5Hz	
	Bypass Overload	110% for long term operation; 110%~125% for 10 mins; 125%~150% for 1 min; >150% for 200 ms	
	Rate Voltage	380/400/415VAC (line-line)	
Output	Rate Frequency	50/60Hz	
	Output PF	1	
	Voltage Regulation	±1%	
	Output THDu	<1% Linear load; <5%, Non-linear load	
	Inverter Overload	<110%, 1 hour; 110%~125%, 10 mins; 125%~150% for 1 min; >150% for 200 ms	
	Rate Frequency	50/60Hz	
	Frequency Precision	± 0.1%	
	Battery	Voltage	±180~264VDC 30pcs derate to 0.7; 32~34pcs derate to 0.8; 36~38pcs derate to 0.9; 40~44pcs
Voltage Precision		1%	
Charge Power		Up to 30% * Output active power	
System	Efficiency	AC Mode	>97%
		Battery Mode	>96%
	Display	LED+Color touch LCD	
	Interface	Standard: RS485, USB, CAN, Programmable Dry Contact Intelligent card slot*2, Extendable dry contact slot	
	Option	SNMP card, AS400 card, Parallel kit, SPD, Dual input kit, LBS	
	Temperature	Operation: 0~40 °C Storage: -40~70 °C	
	Relative Humidity	0~95% Non-condensing	
	Noise(1 meter)	75dB @ 100% load, 70dB @ 45% load	
	Altitude	<1000m. Within 1000m~2000m, 1% power derating for every 100m	
	Application Standard	Safety: IEC/EN 62040-1 EMC: IEC/EN 62040-2 Performance: IEC/EN 62040-3	
Physical	Dimension (W*D*H,mm)	Cabinet	800*1100*2000
		Power Module	550*750*85
	Weight (kg)	Cabinet	443
		Power Module	35.7

RM Series Modular Online UPS 100-600kVA (380V/400V/415V)

The RM Series modular online UPS single cabinet power rating covers from 100kVA to 600kVA, provides the highest power density of 100kW modules in 4U height. 4 units can be paralleled for capacity maximum up to 3.2MW. With the latest technology of 3-level technology and PFC input control, the RM series delivers the best combination of reliability, hot-swappable function and flexibility.



Features

High efficiency

Advanced 3-level technology guarantees, high efficiency operating in double conversion mode up to 96%

Battery neutral free design

Two kind of power module to choose, battery N line free or not, saving instruction cost for customer

High power density

100kVA power module in 4U height, easy for capacity expansion

Reliable Performance

Fully digital control, achieving the input power factor >0.99, input THDi<3% and overall efficiency>96%

Friendly HMI

Ultra-large 10" color touch LCD display for IoT application intuitive information and easier to operate

Multi communication interface

Provide CAN, RS485, USB, SNMP, AS400 and programmable dry contacts

High scalability

The system can be configured from 100kVA to 3.2MW, max 32 power modules in parallel.

Smart sleep function

System can intelligently shutdown some power modules to increase total load rate, achieving higher efficiency

Specification

Model		RM 600/100D	
System Capacity		600kVA	
Power Module Capacity		100kVA/100kW	
Input	Dual Input	Optional	
	Phase	3Phase+Neutral+Ground, 380/400/415VAC (line-line)	
	Rate Frequency	50/60Hz	
	Input Voltage Range	323~478Vac (line-line), full load; 323V~191Vac (line-line), load decrease linearly from 100%~40%; 191V~138V (line-line), load decrease linearly from 45%~35% according to the min. phase voltage	
	Input Frequency Range	40Hz~70Hz	
	Input PF	>0.99	
	Input THDi	<3% (100% Linear load)	
Bypass	Rate Voltage	380/400/415VAC (line-line)	
	Rate Frequency	50/60Hz	
	Input voltage Range	Settable, default -20% ~ +15% Up limit: +10%, +15%, +20%, +25% Down limit: -10%, -15%, -20%, -30%, -40%	
	Bypass Frequency Range	Settable, ±1Hz, ±3Hz, ±5Hz	
	Bypass Overload	110% long term operation; 110% ~ 125% for 5 mins; 125% ~ 150% for 1 min; 150% ~ 400% for 1 s; >400% less than 200 ms	
Output	Rate Voltage	380/400/415VAC (line-line)	
	Rate Frequency	50/60Hz	
	Output PF	1	
	Voltage Regulation	±1%	
	Output THDu	<1% , Linear load, <5% , Non-linear load	
	Inverter Overload	<110% for 1 hour; 110%~125% for 10 mins; 125%~150% for 1 min; >150% for 200 ms	
	Frequency Precision	±0.1%	
Battery	Voltage	±180 ~ 288VDC	
		30 ~ 32pcs derate to 0.7	
		34 ~ 36pcs derate to 0.8	
		38pcs derate to 0.9	
		40 ~ 48pcs	
	Voltage Precision	±1%	
	Charge Power	Up to 15% * Output active power	
System	Efficiency	AC Mode	>96%
		Battery Mode	>95%
	Display	LED+ Color touch LCD screen	
	Interface	RS485, USB, CAN, Programmable Dry Contact, 2 Intelligent slots	
	Option	SNMP Card, AS400 Card, Parallel kit, dual input kit, SPD, LBS, GSM	
	Temperature	Operation: 0 ~ 40 °C Storage: -40~70°C	
	Relative Humidity	0 ~ 95% Non-condensing	
	Noise (1 meter)	75dB @ 100% load, 70dB @ 45% load	
	Altitude	<1000m. Within 1000~2000m, 1% power derating for every 100m rise	
Physical	Dimension (W*D*H,mm)	Cabinet	1000*1100*2000
		Power module	440*795*174
	Weight (kg)	Cabinet	400
		Power module	53.5

HT33 Series Tower Online UPS 60-500kVA (380V/400V/415V)

HT33 series three phase UPS offers advanced technology that increase performance and reliability: three high speed DSPs with completed digital control fully ensure high quality of power supply, high input power factor and low input current distortion. It also offers humanization design: full front access of serviceability and user friendly interface.



Application

- IDC(Internet Data center), ISP, IT Room, Service Center
- Precision instruments, Intelligent equipments

Features

- High efficiency, up to 96%
- High input PF > 0.99; Input current THDi < 3%
- Multi-protection, over-temperature protection with 8 sensors, over-load, battery under voltage, fan failures, short-circuit
- Battery cold start
- Battery management with smart charging control, greatly extend the battery life
- High power density
- Parallel up to 1500kVA
- Modular design of subsystem, convenient for field maintenance
- Friendly operation interface, color touch LCD screen

Specification

MODEL	HT33060X	HT33080X	HT33090X	HT33100X	HT33120X	HT33150X	HT33200X	HT33250X	HT33300X	HT33400X	HT33500X	
System Capacity	60kVA	80kVA	90kVA	100kVA	120kVA	150kVA	200kVA	250kVA	300kVA	400kVA	500kVA	
Input	Dual Input	Standard						Optional		Standard		
	Phase	3 Phase+Neutral+Ground, 380V/400V/415V (line-line)										
	Input Voltage Range	304~478Vac (line-line), full load; 228V~304Vac (line-line), load decreases linearly according to the min. phase voltage										
	Rate Frequency	50/60Hz										
	Input Frequency Range	40Hz ~ 70Hz										
	Input PF	>0.99										
	Input THDi	<3% (100% Linear load)										
Bypass	Rate Voltage	380/400/415Vac (line-line)										
	Rate Frequency	50/60Hz										
	Input Voltage Range	Settable, -40% ~ +25%										
	Bypass Frequency Range	Settable, ±1Hz, ±3Hz, ±5Hz										
	Bypass Overload	125% long term operation 130% for 10 mins 150% for 1 min >150% for 300 ms						110% long term operation 125% for 5 mins 150% for 1 min >150% for 1 s				
Output	Rate Voltage	380/400/415Vac (line-line)										
	Voltage Regulation	1% for balance load; 1.5% for unbalance load										
	Rate Frequency	50/60Hz										
	Frequency Precision	0.1%										
	Output PF	1										
	Output THDu	<1% , Linear load; <5%, Non-linear load										
	Crest Factor	3:1										
	Inverter Overload	110% for 1 hour; 125% for 10 mins; 150% for 1 min; >150% for 200 ms										
Battery	Voltage	±240Vdc										
	Battery Number	40pcs (Settable: even number from 32 to 44)										
	Voltage Precision	±1%										
	Charge Power	up to 20% * Output active power										
	Battery Cold Start	Optional						Standard				
System	Efficiency	AC Mode	95%	96%	95%	96%	95%	96%				
		ECO Mode	99%									
		Battery Mode	95%	96%	95%	96%	95%	96%				
	Display	10.4"(240kVA-500kVA) or 7"(60kVA-200kVA) touch screen LCD + LED + keyboard										
	IP Class	IP 20										
	Interface	RS232, RS485, Programmable Dry Contact, USB										
	Option	SNMP Card, Parallel kit, SPD, LBS, Dust filter										
	Temperature	Operation: 0 ~ 40 °C Storage: -40 ~ 70 °C										
	Relative Humidity	0 ~ 95% Non-condensing										
	Altitude	<1000m. Within 1000m to 2000m, 1% power derating for every 100m rise										
Noise (1 meter)	65dB @ 100% load, 62dB @ 45% load											
Applicable Standards	Safety: IEC/EN 62040-1 EMC: IEC/EN 62040-2 Performance: IEC/EN 62040-3											
Physical	Weight (kg)	170	210	231	210	266	305	350	445	490	700	900
	Dimension W*D*H (mm)	600*980*950	600*980*1150	600*980*1400	600*980*1150	600*980*1400	650*960*1600	650*960*1600	650*970*2000	650*970*2000	1300*1100*2000	1300*1100*2000

HTD33 Series Tower Online UPS 120-200kVA (380V/400V/415V)

HTD33 series high-performance UPS adopts double-conversion online design and DSP full digital control. High input power factor and low harmonic distortion ensure the greenness and environmental protection of the product. The extremely high overall machine efficiency ensures that the system can achieve energy saving while outputting pure sine waves. Provide ideal, uninterrupted high-quality power for computer equipment, communication systems and data rooms.



Application

IDC(Internet Data Center), network servers and workstation, control system, communication system, office, PC etc

Features

- High efficiency, up to 96%
- High input PF > 0.99; Input current THDi < 3%
- Multi-protection, over-temperature protection with 8 sensors, over-load, battery under voltage, fan failures, short-circuit
- Intelligent battery management, support lithium battery
- Supports multiple languages, Simplified Chinese, Traditional Chinese, English, Russian, Italian, Korean, Portuguese, Spanish, German, Polish, French, Turkish, Czech, Serbian
- High power density
- Full front maintenance, supports up and bottom cable entry methods. Save installation space
- Modular design of subsystem, convenient for on site maintenance
- Friendly operation interface, equipped with large-screen LCD touch screen and control keyboard
- Rich fault records and large-capacity historical log storage space up to 2000

Specification

Model	HT33120D	HT33160D	HT33200D
System Capacity	120kVA	160kVA	200kVA
Input	Dual Input	Standard	
	Phase	3P+N+PE, 380/400/415VAC (line-line)	
	Input Volatge Range	323 ~ 478VAC (line-line), full load	
	Rate Frequency	50/60Hz	
	Input Frequency Range	40Hz ~ 70Hz	
	Input PF	>0.99	
Bypass	Input THDi	<3% (100% Linear load)	
	Rate Voltage	380/400/415VAC (line-line)	
	Rate Frequency	50/60Hz	
	Input Volatge Range	Settable -40%~+25%, default -20% ~ +15%	
	Bypass Frequency Range	Settable, ±1Hz, ±3Hz, ±5Hz	
	Bypass Overload	110%, long ter operation 125%~130%, 10 mins 130%~150%, 1 min >150%, 300 ms	
Output	Rate Voltage	380/400/415VAC (line-line)	
	Rate Frequency	50/60Hz	
	Output PF	1	
	Volatge Precision	±1%	
	Output THDu	<1%, Linear load; <5%, Non-linear load (IEC/EN62040-3)	
	Inverter Overload	<110%, 1 hour 110%~125%, 10 mins 125%~150%, 1 min >150%, 200ms	
Battery	Frequency Precision	50/60Hz±0.1%	
	Voltage	±240VDC	
	Battery Number	40~48pcs 30pcs derate to 0.7 32~34pcs derate to 0.8 36~38pcs derate to 0.9	
	Volatge Precision	1%	
	Charge Power	15% *Output active power	
	Battery Cold Start	Standard	
System	Efficiency	AC Mode >96% Battery Mode >95%	
	Display	LCD + LED + color touch screen	
	Interface	RS485, USB, CAN, Programmable Dry Contat, Intelligent slot *2, Expandable dry contact slot *1	
	Option	SNMP card, Intelligent AS400 Card, Pallele kit, SPD, LBS, GSM, RS485 Expansion Card	
	Temperature	Operation: 0 ~ 40 °C Storage: -40 ~ 70 °C	
	Relative Humidity	0 ~ 95% Non-condensing	
Physical	Noise (1 meter)	75dB @ 100% load, 70dB @ 45% load	
	Altitude	<1000m, within 1000~2000m, 1% power derating for every 100m rise	
	Dimension W*D*H (mm)	480*1100*1200	
	Weight (kg)	187	200

HT33 Series Tower Online UPS 10-40kVA (380V/400V/415V)

HT33 series UPS applies advanced technology that increases performance and reliability: two high speed DSPs with completed digital control to ensure high quality of power supply, high input power factor and low input current distortion.



Application

- IDC(Internet Data center), ISP, Computer Room, Service Center
- Precision instruments, Intelligent equipments

Features

- High efficiency, up to 96%
- High input PF > 0.99; Input current THDi < 4%
- Multi-protection, over-temperature protection with 8 sensors, over-load, battery under voltage, fan failures, short-circuit
- Four circuit breakers, providing full protection when fault happens
- Battery cold start
- Battery management with smart charging control, greatly extend the battery life
- Parallel up to 4 units
- Friendly operation interface, high-resolution LCD screen

Specification

MODEL		HT33010XS	HT33015XS	HT33020XS	HT33030XS	HT33040XS	
		HT33010XL	HT33015XL	HT33020XL	HT33030XL	HT33040XL	
System Capacity		10kVA	15kVA	20kVA	30kVA	40kVA	
Input	Dual Input	Standard					
	Phase	3 Phase+Neutral+Ground, 380V/400V/415V (line-line)					
	Input Voltage Range	304~478Vac (line-line), full load; 228V~304Vac (line-line), load decreases linearly according to the min. phase voltage					
	Rate Frequency	50/60Hz					
	Input Frequency Range	40Hz ~ 70Hz					
	Input PF	>0.99					
	Input THDi	<4% (100% Linear load)		<3% (100% Linear load)			
Bypass	Rate Voltage	380/400/415Vac (line-line)					
	Rate Frequency	50/60Hz					
	Input Voltage Range	Settable, -40% ~ +25%					
	Bypass Frequency Range	Settable, ±1Hz, ±3Hz, ±5Hz					
	Bypass Overload	125% long term operation; 130% for 10 mins; 150% for 1 min					
Output	Rate Voltage	380/400/415Vac (line-line)					
	Voltage Regulation	1% for balance load; 1.5% for unbalance load					
	Rate Frequency	50/60Hz					
	Frequency Precision	0.1%					
	Output PF	1		0.9			
	Output THDu	<1%, Linear load; <5.5%, Non-linear load					
	Crest Factor	3:1					
	Inverter Overload	110% for 1 hour; 125% for 10 mins; 150% for 1 min; >150% for 200 ms					
Battery	Voltage	±240Vdc					
	Battery Number	40pcs (Settable: even number from 32 to 44)					
	Voltage Precision	±1%					
	Charge Power	up to 20% * Output active power					
	Battery Cold Start	Optional					
System	Efficiency	AC Mode	95.0%			96.0%	
		ECO Mode	98.0%				
		Battery Mode	95.0%			96.0%	
	Display	LCD + LED + keyboard					
	IP Class	IP 20					
	Interface	RS232, RS485					
	Option	SNMP Card, Parallel kit, USB, Programmable Dry Contact					
	Temperature	Operation: 0 ~ 40 °C Storge: -40 ~ 70 °C					
	Relative Humidity	0 ~ 95% Non-condensing					
	Altitude	<1000m. Within 1000m to 2000m, 1% power derating for every 100m rise					
	Noise (1 meter)	55dB @ 50% load					
Applicable Standards	Safety: IEC/EN 62040-1 EMC: IEC/EN 62040-2 Performance: IEC/EN 62040-3						
Physical	Weight (kg)	51.5	51.5	89	89	140	
	Dimension W*D*H (mm)	31	31	50	52	61	
		250*840*715	250*840*715	350*738*1335	350*738*1335	500*840*1400	
	250*660*530	250*660*530	250*680*770	250*680*770	250*836*770		

HT33-TX Series Tower Online UPS 10-40kVA (380V/400V/415V)

HT33-TX series in-built transformer three phase UPS applies advanced technology that increases performance and reliability: two high speed DSPs with completed digital control fully ensure high quality of power supply, high input power factor and low input current distortion. With in-built transformer, the HT33-TX is providing more safety to critical load.



Application

- IDC(Internet Data center), ISP, IT Room, Service Center
- Precision instruments, Intelligent equipments

Features

- In-built galvanic isolation transformer
- High input PF > 0.99; Input current THDi < 4%
- Multi-protection, over-temperature protection with 8 sensors, over-load, battery under voltage, fan failures, short-circuit
- Four circuit breakers, providing full protection when fault happens
- Battery cold start
- Battery management: smart charging control, auto maintenance, greatly extend the battery life
- Friendly operation interface, high-resolution LCD screen

Specification

MODEL	HT33010X-TX	HT33020X-TX	HT33030X-TX	HT33040X-TX
System Capacity	10kVA	20kVA	30kVA	40kVA
Input	Dual Input	Standard		
	Phase	3 Phase+Neutral+Ground, 380V/400V/415V (line-line)		
	Input Voltage Range	304~478Vac (line-line), full load; 228V~304Vac (line-line), load decreases linearly according to the min. phase voltage		
	Rate Frequency	50/60Hz		
	Input Frequency Range	40Hz ~ 70Hz		
	Input PF	>0.99		
	Input THDi	<4%	<3%	
Bypass	Rate Voltage	380/400/415Vac (line-line)		
	Rate Frequency	50/60Hz		
	Input Voltage Range	Settable, -40% ~ +25%		
	Bypass Frequency Range	Settable, ±1Hz, ±3Hz, ±5Hz		
	Bypass Overload	125% long term operation; 130% for 10 mins; 150% for 1 min		
Output	Rate Voltage	380/400/415Vac (line-line)		
	Voltage Regulation	1% for balance load; 1.5% for unbalance load		
	Rate Frequency	50/60Hz		
	Frequency Precision	0.1%		
	Output PF	0.9		
	Output THDu	<1%, Linear load; <5.5%, Non-linear load		
	Crest Factor	3:1		
	Inverter Overload	110% for 1 hour; 125% for 10 mins; 150% for 1 min; >150% for 200 ms		
Battery	Voltage	±240Vdc		
	Battery Number	40pcs (Settable: even number from 32 to 44)		
	Voltage Precision	±1%		
	Charge Power	up to 20% * Output active power		
	Battery Cold Start	Optional		
System	Efficiency	AC Mode	92.0%	
		ECO Mode	95.0%	
		Battery Mode	92.0%	
	Display	LCD + LED + keyboard		
	IP Class	IP 20		
	Interface	RS232, RS485		
	Option	SNMP Card, Parallel kit, USB, Programmable Dry Contact		
	Temperature	Operation: 0 ~ 40 °C Storge: -40 ~ 70 °C		
	Relative Humidity	0 ~ 95% Non-condensing		
	Altitude	<1000m. Within 1000m to 2000m, 1% power derating for every 100m rise		
	Noise (1 meter)	55dB @ 50% load		
	Applicable Standards	Safety: IEC/EN 62040-1 EMC: IEC/EN 62040-2 Performance: IEC/EN 62040-3		
Physical	Weight (kg)	200	220	240
	Dimension W*D*H (mm)	250*658*955	350*757*1335	350*757*1335

HR33 Series Rack Online UPS 10-40kVA (380V/400V/415V)

The HR33 Series Rack is double conversion online UPS with fully DSP controlled technology. With its flexible configuration of 3/3 and 3/1, compact design, it's the ideal choice for modern data center.



Application

IDC(Internet Data Center), network servers and workstation, control system, communication system, office, PC etc

Features

- **Rack Design**
Rack design, compatible with 19" standard rack cabinet, convenient to be integrated with servers
- **Friendly Interface**
5.5" touch color LCD with graphic display, more information displayed and easier for customer to operate
- **Flexible configuration**
The system of 10kVA and 20kVA can be configured to 3/3 and 3/1
- **Intelligent charging management**
The system intelligently control the whole process of the charging and discharging, effectively improving the life time of the battery

Specification

MODEL	HR33010CL	HR33015CL	HR33020CL	HR33025CL	HR33030CL	HR33040CL
System Capacity	10kVA/10kW	15kVA/15kW	20kVA/20kW	25kVA/25kW	30kVA/30kW	40kVA/40kW
Input	Dual Input	Standard				
	Phase	3 Phase+Neutral+Ground, 380V/400V/415V(line-line)				
	Input Voltage Range	304~478Vac (line-line), full load; 228V~304Vac (line-line), load decreases linearly according to the min. phase voltage				
	Rate Frequency	50/60Hz				
	Input Frequency Range	40Hz ~ 70Hz				
	Input PF	>0.99				
Bypass	Input THDi	<4% (100% Linear load)	<3% (100% Linear load)			
	Rate Voltage	380/400/415Vac (line-line)				
	Rate Frequency	50/60Hz				
	Input Voltage Range	Settable, -40% ~ +25%				
	Bypass Frequency Range	Settable, ±1Hz, ±3Hz, ±5Hz				
Output	Bypass Overload	125% long term operation; 130% for 10 mins; 150% for 1 min, >150% for 1s				
	Rate Voltage	380/400/415Vac (line-line)				
	Voltage Regulation	1% for balance load; 1.5% for unbalance load				
	Rate Frequency	50/60Hz				
	Frequency Precision	0.1%				
	Output PF	1				
	Output THDu	<1%, Linear load; <5.5%, Non-linear load	<1.5%, Linear load; <6%, Non-linear load			
	Crest Factor	3:1				
Battery	Inverter Overload	110% for 1 hour; 125% for 10 mins; 150% for 1 min; >150% for 200 ms				
	Voltage	±240Vdc				
	Battery Number	40pcs (Settable: even number from 32 to 44)				
	Voltage Precision	±1%				
	Charge Power	up to 20% * Output active power				
System	Battery Cold Start	Standard				
	Efficiency	AC Mode	95%	95.5%	96%	
		ECO Mode		98%		
		Battery Mode	94.5%	95%	95.5%	
	Display	LCD + LED + keyboard				
	IP Class	IP 20				
	Interface	RS232 for 10-25kVA, USB for 30-40kVA, RS485, Programmable Dry Contact				
	Option	LBS for HR33020CL and HR33025CL, SNMP Card, Parallel kit				
	Temperature	Operation: 0 ~ 40 °C Storge: -40 ~ 70 °C				
	Relative Humidity	0 ~ 95% Non-condensing				
	Altitude	<1000m. Within 1000m to 2000m, 1% power derating for every 100m rise				
	Noise (1 meter)	65dB @ 100% load, 62dB @ 45% load				
Physical	Applicable Standards	Safety: IEC/EN 62040-1 EMC: IEC/EN 62040-2 Performance: IEC/EN 62040-3				
	Weight (kg)	25	30	41		
	Dimension W*D*H (mm)	438*780*130	438*780*130	438*700*174		

HT31 Series Tower Online UPS 10-40kVA (220V/230V/240V)

HT31 series is online double-conversion UPS with full DSP control technology. With high input and output power factor, self-adjusting output frequency and network management, HT31 is a perfect choice for computers, telecommunication equipments and other sensitive devices.



Application

IDC(Internet Data Center), network,servers and workstations, office etc

Features

Common features for 10-40kVA

- Full protection of overvoltage, circuit short and over temperature
- Auto fan speed adjustment
- Abundant interface: RS232, USB, SNMP, Intelligent Card
- Parallel up to 2 units

Unique features for 10-20kVA

- Output PF=1
- Small size with higher power density
- Digital Charger, adjustable from 1A to 5A
- 12A charger for option, charging for large capacity batteries

Specification

MODEL	HT3110XL	HT3115XL	HT3120XL	HT3140L
Capacity	10kVA	15kVA	20kVA	40kVA
Phase	Three phase in, Single phase out			
Input voltage range	190Vac~499Vac			228Vac~478Vac
	100% load@ >305Vac, 90% load@ >266Vac 75% load@ >228Vac, 50% load@ >190Vac			100% load@ >305Vac 90% load@ >266Vac 75% load@ >228Vac
Input PF	≥0.99			
Input THDi	≤4% (100% Linear load)			≤3% (100% Linear load)
Input frequency range	40Hz-70Hz			
Output PF	1			0.9
Output voltage	220V/230V/240V			
Voltage regulation	1%			
THDu	≤1% (full linear load) ≤3% (full non-linear load)			≤1% (full linear load) ≤5% (full non-linear load)
Battery voltage	192Vdc			±240Vdc
Battery type/number	External			
System efficiency	Normal: 94.5%;		Normal: 95%	
	ECO :98%;			
Noise(1 meter away)	<50dB@<70%load; <58dB@>70%load			65dB @ 100%load 62dB @ 45%load
Overload capability (Inverter mode)	110%: for 10 min ;130%:for 1 min; 150%: for 30 sec (shut down the bypass after 1 min)			
Overload capability (Battery mode)	110%: shut down after 1 min; 130%: shut down after 10 sec; >130%: shut down after 200 ms			110%: shut down after 10 min; 125%:shut down after 10 sec; >125%: shut down after 1 sec
Crest factor	3:1			
Display	LED+LCD			10.4" color touch screen LCD+LED
Interface	Standard:RS232, EPO Optional: RS485, USB, SNMP, Dry contacts			Standard: RS232, RS485 USB, Dry contacts Optional: SNMP, parallel kit Battery cold start
W*D*H(mm)	190*485*336	190*485*480	190*485*480	600*980*950
Weight(kg)	22	33	33	170

HR31 Series Rack Online UPS 15-20kVA (220V/230V/240V)

HR31 series is online double-conversion UPS with full DSP control technology. With high input and output power factor, self-adjusting output frequency and network management, HR31 is a perfect choice for computers, telecommunication equipments and other sensitive devices.

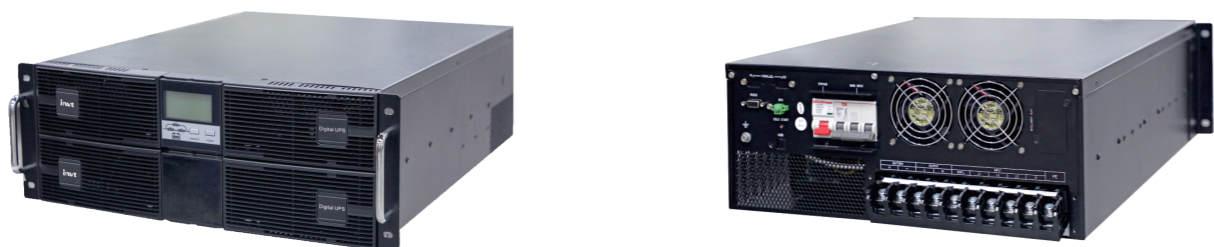

Application

IDC(Internet Data Center), network, servers and workstations, office etc

Features

- Full protection of overvoltage, circuit short and over temperature
- Auto fan speed adjustment
- High efficiency, up to 96%
- Parallel up to 2 units
- Output PF=1
- Digital Charger, adjustable from 1A to 5A
- 12A charger for option, charging for large capacity batteries
- Self-aging mode, system can simulate full load test without connecting real load, saving more than 90% energy

Specification

MODEL	HR3115XL	HR3120XL
Capacity	15kVA	20kVA
Phase	Three phase in, Single phase out	
Input voltage range	190Vac~499Vac	
	100% load@ >305Vac, 90% load@ >266Vac 75% load@ >228Vac, 50% load@ >190Vac	
Input PF	≥0.99	
Input THDi	≤4% (100% Linear load)	
Input frequency range	40Hz-70Hz	
Output PF	1	
Output voltage	220V/230V/240V	
Voltage regulation	1%	
THDu	≤1% (full linear load)	
	≤3% (full non-linear load)	
Battery voltage	192Vdc	
Battery type/number	External	
System efficiency	Normal: 95%	
	ECO: 98%;	
Noise(1 meter away)	<62dB	
Overload capability (Inverter mode)	110%: for 10 min; 125%: for 1 min;	
	150%: for 30 sec (shut down the bypass after 1 min)	
Overload capability (Bypass mode)	<125%: long term operation; 130%:shut down after 5 min;	
	150%: shut down after 1min; >150%: shut down after 200 ms	
Crest factor	3:1	
Display	LED+LCD	
Interface	Standard: RS232, EPO	
	Optional: RS485, USB, SNMP, Dry contacts	
W*D*H(mm)	438*744*173	
Weight(kg)	33	

HT11 Series Tower Online UPS

6-20kVA (220V/230V/240V)

HT11 series, ranging from 6kVA to 20kVA, is double conversion online UPS with fully DSP controlled technology. The single phase UPS applies the advanced 3-level technology, achieving efficiency up to 95%. With its compact design of high power density (kW=kVA), HT11 series makes it an ideal choice for computers, telecommunication equipment and sensitive devices.



Application

IDC(Internet Data Center), network, servers and workstations, office etc

Features

- High efficiency, up to 95%
- Intelligent charging management, effectively improving the life time of battery
- kVA=kW, Output PF=1
- Smaller size with higher power density
- 3 level of technology, compatible with complicated load
- Parallel up to 2 units
- Battery number can be set on LCD
- 12A charger for option, charging for large capacity batteries

Specification

MODEL	HT1106XS	HT1106XL	HT1110XS	HT1110XL	HT1115XL	HT1120XL
Capacity	6kVA/6kW	6kVA/6kW	10kVA/10kW	10kVA/10kW	15kVA/15kW	20kVA/20kW
Phase	Single phase in , Single phase out					
Input voltage range	110Vac~288Vac					
	100% load@ > 176Vac; 90% load@ > 160Vac 80% load@ > 140Vac; 60% load@ > 110Vac					
Input THDi	≤4%@100% load; ≤6%@50% load (linear load)					
Input PF	≥0.99					
Input frequency range	40Hz-70Hz					
Output PF	1					
Output voltage	220V/230V/240V					
Voltage regulation	±1%					
THDu	≤1%(linear); ≤5% (non-linear)				≤1%(linear); ≤3% (non-linear)	
Battery voltage	192Vdc					
Battery type/number	12V, 7Ah*16	External	12V, 9Ah*16	External	External	
System efficiency	Normal mode: 95%					
Noise(1 meter away)	<48dB@<70%load; <58dB@>70%load				<50dB@<70%load; <58dB@>70%load	
Overload capability (Inverter mode)	110%: for 10 min;125%: for 1 min; 150%: for 30 second					
Overload capability (Battery mode)	110%: shut down after 1 min; 130%:shut down after 10 second; >130%: shut down after 200 ms					
Crest factor	3:1					
Display	LED+LCD					
Interface	Standard:RS232 Optional: SNMP, USB, RS485, Dry Contacts, Parallel Kit					
W*D*H (mm)	190*426*705	190*426*336	190*485*705	190*485*336	190*485*480	
Package Weight (kg)	56	14	60	16	33	

HT11 Series Tower Online UPS 1-3kVA (220V/230V/240V)

HT11 series is online double-conversion UPS with full DSP control technology. With high input and output power factor, self-adjusting output frequency and network management, HT11 is a perfect choice for computers, telecommunication equipments and other sensitive devices.



Application

IDC(Internet Data Center), network, servers and workstations, control system, communication system, office, PC etc

Features

- Wide range of input voltage while input PF>97%
- Output PF is 0.9, more powerful load capability
- Full protection of overvoltage, circuit short and over temperature
- LCD/LED display, monitoring all the operation status
- Auto fan speed adjustment
- Reliable and stable pure sine wave output

Specification

MODEL	I	HT1101S	HT1101L	HT1102S	HT1102L	HT1103S	HT1103L
	II	HT1101S-II	HT1101L-II	HT1102S-II	HT1102L-II	HT1103S-II	HT1103L-II
Capacity		1kVA		2kVA		3kVA	
Phase		Single Phase in, Single Phase out					
Input voltage		110Vac-288Vac					
		100% load@>176Vac; 80% load@>154Vac; 70% load@>132Vac; 50% load@>110Vac					
Input PF		≥0.97					
Input frequency		40Hz ~ 70Hz					
Output PF	I	0.9					
	II	0.8					
Output voltage		220V/230V/240V					
Voltage regulation		± 1 %					
THDu		≤2%(linear)					
		≤5.5%(non-linear)	≤5%(non-linear)	≤5%(non-linear)	≤5%(non-linear)	≤5%(non-linear)	≤5%(non-linear)
Crest factor		3:1					
Efficiency		87.0%		91.0%		90.0%	
Noise		<43dB@<70%Load, <47dB@>70%Load		<45dB@<70%Load, <50dB@>70%Load		<45dB@<70%Load, <50dB@>70%Load	
		Inverter	105% ~ 130%: to bypass after 1 min; 150%: to bypass after 30 sec				
Overload capability		Battery	105% ~ 130%: shut down after 10 sec; 150%: shut down after 5 sec				
Battery voltage	I	36Vdc		72Vdc		96Vdc	
	II	24Vdc		48Vdc		72Vdc	
Battery type/numbe	I	12V, 7Ah*3	External	12V, 7Ah*6	External	12V, 7Ah*8	External
	II	12V, 7Ah*2	External	12V, 7Ah*4	External	12V, 7Ah*6	External
Max charging current		1A	8A	1A	8A	1A	8A
Interface		RS232, EPO					
Optional		USB(B Type), SNMP, Dry contact					
W*D*H(mm)	I	144*353*222		190*375*336		190*427*336	
	II	144*353*222		190*374*336		190*374*336	
Weight(kg)	I	10.5	5	21	8.5	24.5	9.5
	II	10	6	17	11	22	12

HTC11 Series Tower Online UPS 1-3kVA (220V/230V/240V)

HTC series is an online double-conversion UPS with fully digital control technology. This upgraded new generation of UPS not only has an ultra-high input and output power factor, but also increases the efficiency on the basis of the original 5%. HTC11 with adjustable 12A charger is a perfect choice for PC and other sensitive devices that request longer backup time.



Application

IDC (Internet Data Center), network, servers and workstations, control system, communication system, office, PC etc.

Features

- Wide range of input voltage while input PF>0.99
- LCD/LED display, monitoring all the operation status
- Output PF of 1, upgraded overload capability
- Auto fan speed adjustment
- Full protection of over-voltage and short-circuit
- External environment and battery temperature sensor
- Multiple communication interface: RS232, RS485, AS400, dry contact, USB and SNMP card
- 1-12A adjustable charger with more flexibility
- Support Lithium battery

Specification

MODEL	HT1101CL	HT1101CS	HT1102CL	HT1102CS	HT1103CL	HT1103CS		
System Capacity	1kVA		2kVA		3kVA			
Input	Phase						Single Phase in, Single Phase out	
	Input Voltage Range						110VAC~300VAC	
	Input Power Factor						≥0.99	
	Input Frequency						50/60±5Hz (Default), ±3Hz/±10Hz (settable)	
	Input Frequency Range						40Hz~70Hz	
	Frequency Adaptable						Settable	
Output	Output Voltage						200/208/220/230/240VAC	
	Voltage Regulation						± 1 %	
	Rate Frequency						50/60Hz	
	Frequency Range						±0.1%	
	Output THDu						≤2% THD, linear load; ≤ 5% THD, non-linear load	
	Output PF						1 (0.9 for 200VAC/208VAC)	
	Crest Factor						3:1	
	Dynamic Response						≤5% (0% - 100% -0%)	
	Dynamic Recovery						≤40ms (0% - 100% -0%)	
	Overload Capability	Inverter						102%~110% for 30mins; 110%~125% for 10mins; 125%~150% for 30s
		Battery						102%~110% for 1min; 110%~125% for 10s; 125%~150% for 5s
		Bypass						<130%: long term operation; <150% for 10mins; <180% for 5s
Battery	DC Voltage						36VDC 72VDC 96VDC	
	Number/Type						External 12V, 7Ah*3 External 12V, 7Ah*6 External 12V, 7Ah*8	
	Charging Voltage						Settable	
	Max Charging Current						1-12A 1A 1-12A 1A 1-12A 1A	
	Battery Cold Start						Standard	
System	Efficiency	Normal Mode		94.5%@100% load	95.5%@100% load	95.5%@100% load		
		ECO Mode		96%	97%	97%		
		Battery Mode		89.5%@100% load	91.5%@100% load	91.5%@100% load		
	Noise (1m away)		<43dB@<60%load <47dB@>60%load	<50dB@<60%load <55dB@>60%load	<50dB@<60%load <55dB@>60%load			
	Display						LED+LCD	
	Interface						RS232, input socket (IEC C14 for 1K, C20 for 2-3K) output socket (2 National standard sockets for 1K, 4 National standard sockets for 2K 3 National standard sockets+1 20A connecting terminal for 3K)	
Optional						RS485, USB, AS400 Dry Contact, SNMP Card, EPO External Battery Temperature, RJ45 Surge Protection, Dust net		
Physical	W*D*H(mm)						144*354*224 144*354*224 144*410*223 190*405*330 144*410*223 190*405*330	
	W*D*H(mm)(Package size)						240*448*320 240*448*320 240*510*320 285*520*406 240*510*320 285*520*406	
	Net Weight (KG)						4.3 10.3 5.8 21.1 6.2 25.5	
	Gross Weight (kg)						5.6 11.6 7.1 23 7.5 27.5	

HR11 Series Rack Online UPS 1-10kVA (220V/230V/240V)

HR11 series, ranging from 1kVA to 10kVA, is double conversion online rack UPS with fully DSP controlled technology. The single phase of 6-10kVA UPS applies the advanced 3-level technology, achieving efficiency up to 95%. With its compact design of high power density (kW=kVA) in 2U height, HR11 series makes it an ideal choice for computers, telecommunication equipment and other sensitive devices.



Application

IDC(Internet Data Center), network, servers and workstations, control system, communication system, office, PC etc

Features

Common features for 1-10kVA

- Wide range of input voltage while input PF>99%
- 19" standard cabinet and battery cabinet
- Full protection of overvoltage, circuit short and over temperature
- LCD/LED display, monitoring all the operation status
- Automatic fan speed adjustment
- Abundant interface: RS232, USB, SNMP, Intelligent Card

Unique features for 6-10kVA

- High efficiency, up to 95%
- kVA=kW, output PF=1
- Intelligent charging management, effectively improving the life time of battery
- 3 level of technology, compatible with complicated load

Specification

MODEL	HR1101S	HR1102S	HR1103S	HR1106XS	HR1110XS
	HR1101L	HR1102L	HR1103L	HR1106XL	HR1110XL
Capacity	1kVA	2kVA	3kVA	6kVA	10kVA
Input voltage range	110Vac-288Vac			110Vac-288Vac	
	100% load@>176Vac; 80% load@>154Vac 70% load@>132Vac; 50% load@>110Vac			100% load@ > 176Vac; 90% load@ > 160Vac 80% load@ > 140Vac; 60% load@ > 110Vac	
Input frequency	40-70Hz				
Input PF	≥0.97			≥0.99	
Voltage regulation	±1 %				
Output frequency	50/60Hz				
Output PF	0.9			1.0	
Overload capability (Inverter mode)	105%-130%: to bypass 1 min; 150%: to bypass after 30 sec			110%:for 10 min;125%:for 1min ; 150%: for 30 sec	
Overload capability (Battery mode)	105%-130%: shutdown after 10 sec; 150%: shutdown after 5 sec			110%: shut down after 1 min; 130%: shut down after 10 sec; >130%: shut down after 200 ms	
Crest factor	3:1				
Efficiency	87%	91%	90%	95%	
Display	LED+LCD				
Battery voltage	36Vdc	72Vdc	96Vdc	192Vdc	
Battery type/number	12V,7Ah*3	12V,7Ah*6	12V,7Ah*8	12V,7Ah*16	12V,9Ah*16
	External				
Interface	RS232, EPO				
Optional	USB, SNMP, Dry contacts			USB, SNMP, Dry contacts	
Operation temperature	0-40°C				
Relative humidity	0-95% (non-condensing)				
W*D*H(mm)	440*430*86	440*480*173	440*480*173	440*660*173	
	440*430*86	440*480*86	440*480*86	440*550*86	
Weight(kg)	11.5	25	31	59	67
	7	8	9.5	17.5	20.5

HRC11 Series Tower Online UPS 1-3kVA (220V/230V/240V)

HRC series, range from 1kVA to 10kVA, is double conversion online rack UPS with fully digital control technology. This upgraded new generation of UPS is compatible with lithium batteries, and charging current can be increased up to 12A. With its compact design of high density (Output PF =1) in 2U height, HRC series makes it deal choice for computers, telecommunication equipment and other sensitive device.



Application

IDC (Internet Data Center), network, servers and workstations, control system, communication system, office, PC etc.

Features

- Wide range of input voltage while input PF>0.99
- LCD/LED display, monitoring all the operation status
- Output PF of 1, upgraded overload capability
- External environment and battery temperature sensor
- 19" standard cabinet and battery cabinet
- 1-12A adjustable charger with more flexibility
- Multiple communication interface: RS232, RS485, AS400, dry contact, USB and SNMP card
- Intelligent charging management, effectively improving the life time of battery
- Auto fan speed adjustment
- Support Lithium battery

Specification

MODEL	HR1101CL	HR1101CS	HR1102CL	HR1102CS	HR1103CL	HR1103CS		
System Capacity	1kVA		2kVA		3kVA			
Input	Phase	Single Phase in, Single Phase out						
	Input Voltage Range	110VAC~300VAC						
	Input Power Factor	≥0.99						
	Input Frequency	50/60±5Hz (Default), ±1Hz/±3Hz/±10Hz (settable)						
	Input Frequency Range	40Hz~70Hz						
	Frequency Adaptable	Settable						
Output	Output Voltage	200/208/220/230/240VAC						
	Voltage Regulation	± 1 %						
	Rate Frequency	50/60Hz						
	Frequency Range	±0.1%						
	Output THDu	≤2% THD, linear load; ≤ 5% THD, non-linear load						
	Output PF	1 (0.9 for 200VAC/208VAC)				0.9		
	Crest Factor	3:1						
	Dynamic Response	≤5% (0% - 100% -0%)						
	Dynamic Recovery	≤40ms (0% - 100% -0%)						
	Overload Capability	Inverter	102%~110% for 30mins; 110%~125% for 10mins; 125%~150% for 30s					
Battery		102%~110% for 1min; 110%~125% for 10s; 125%~150% for 5s						
Bypass		<130%: long term operation; <150% for 10mins; <180% for 5s						
Battery	DC Voltage	36V/48Vdc	36Vdc	72V/96Vdc	72Vdc	96Vdc	72Vdc	
	Number/Type	External	12V, 7Ah*3	External	12V, 7Ah*6	External	12V, 9Ah*6	
	Charging Voltage	Settable						
	Max Charging Current	1-12A	1A	1-12A	1A	1-12A	1A	
	Battery Cold Start	Standard						
System	Efficiency	Normal Mode	94.5%@100% load		95.5%@100% load		95.5%@100% load	
		ECO Mode	98%		98%		98%	
		Battery Mode	89.5%@100% load		91.5%@100% load		91.5%@100% load	
	Noise (1m away)	<43dB@<60%load	<50dB@<60%load		<50dB@<60%load		<55dB@>60%load	
		<47dB@>60%load	<55dB@>60%load		<55dB@>60%load		<55dB@>60%load	
	Display	LED+LCD						
Interface	RS232, input socket (IEC C14 for 1K, C20 for 2-3K) output socket (4 National standard sockets)							
Optional	RS485, USB, AS400 Dry Contact, SNMP Card, EPO External Battery Temperature, RJ45 Surge Protection, Dust net							
Physical	W*D*H(mm)	440*377*86	440*427*86	440*427*86	440*577*86	440*427*86	440*577*86	
	Net weight (kg)	5.5	12.5	7	21.9	7.3	24.9	

Rack battery cabinet

Rack battery cabinet is special designed for IDC solution, compatible with 19" standard rack cabinet, online maintenance and convenient to be integrated into servers system.

Each battery package can install 40pcs 7 or 9Ah batteries, and connecting multiple packages in parallel to get longer backup time.

Solution

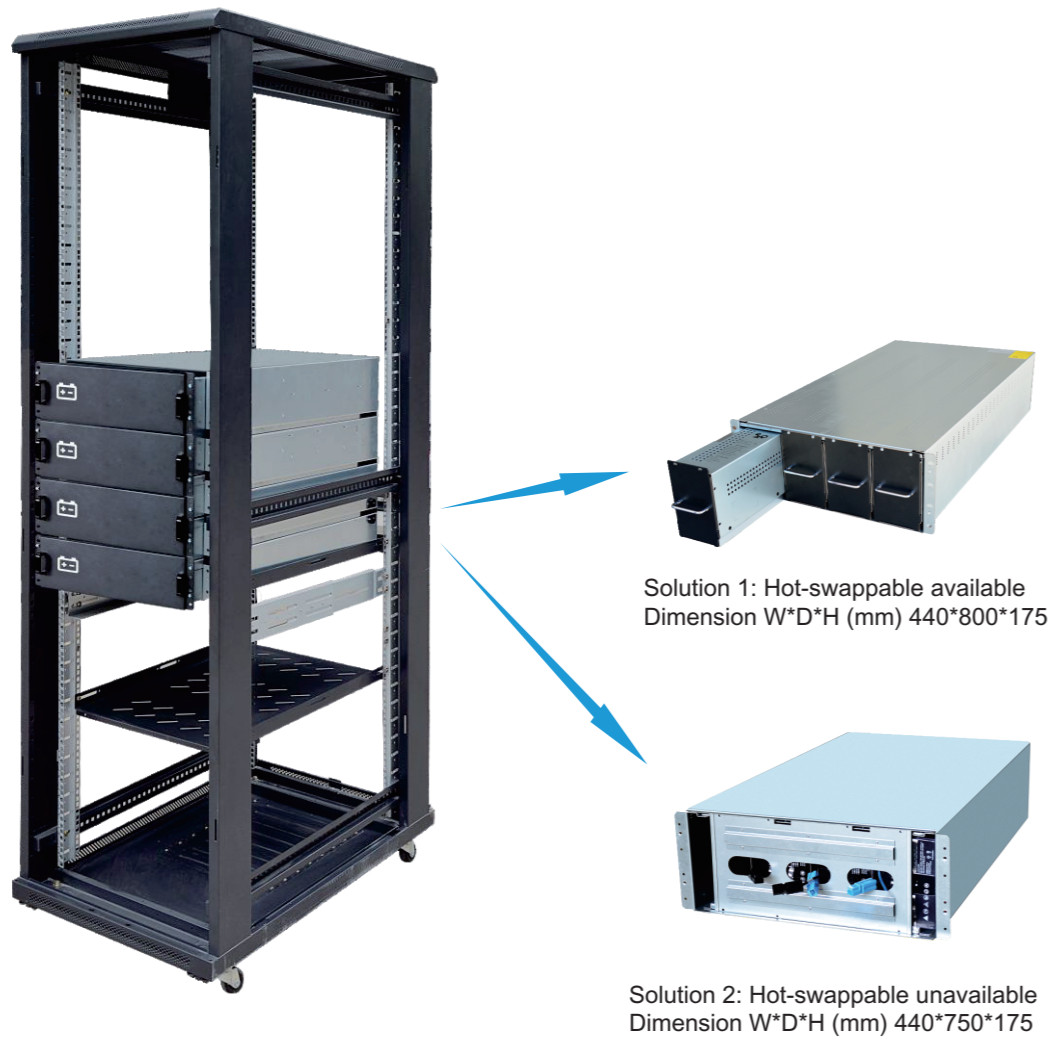

Smart Remote Monitor

Smart Remote Monitor has been specifically designed to provide detailed information of the running UPS over a long distance, which is suitable to be used in data center, IDC, monitor and control room and other applications. The Smart Remote Monitor displays and monitors the parameters and status of the UPS in real time, ensuring the safe running of the UPS system.

Solution

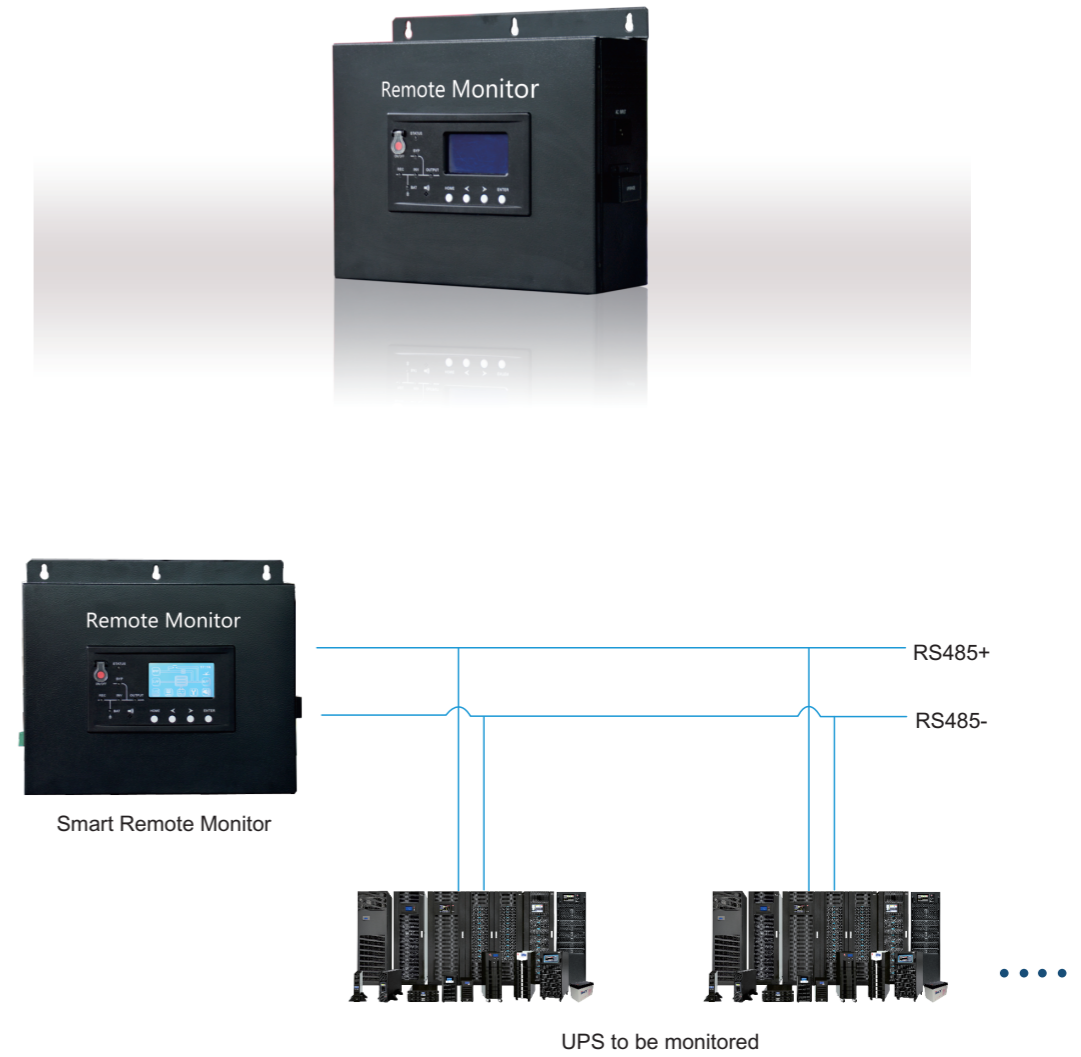

Smart Charging Module

Smart charging module is designed for large current charging application where long back up time is required. There are 2 kinds of charging module, 15Amp and 50Amp. 15Amp current charging module is compatible with 10/15kVA power module based RM series 10-90kVA and can provide additional maximum current of 15Amp*N; 50Amp current charging module is compatible with 30kVA power module based RM series 25-600kVA and modular-designed HT33 series 60-120kVA and can provide additional maximum current of 50Amp*N.

Features

Modular and hot-swappable design

Modular and hot-swappable design, the same size and outlook as power module

Large charging current

Each charging module can provide a maximum current of 15Amp (Or 50Amp) and charging current can be set from 0-15Amp (Or 0-50Amp) on site

Compatibility

Compatible with 15kVA (Or 30kVA) power modules, easy for the UPS to expand charging capacity

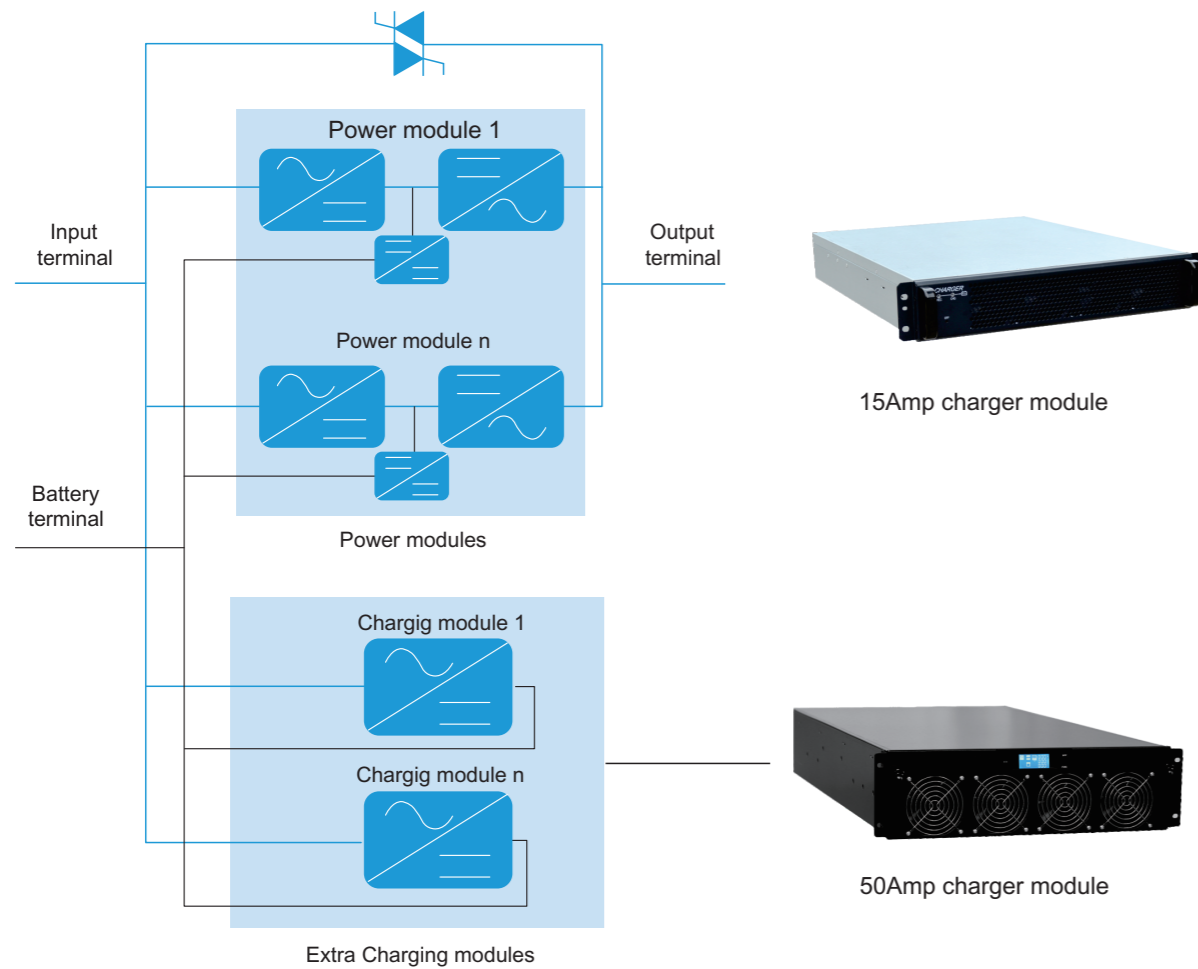

Energy Absorbing Unit

The intelligent Back-feed Absorbing Unit (BAU) is designed to cooperate with the UPS for industrial applications, where the energy is feeding back to the UPS from load. BAU provides an excellent solution for these cases.

Application

Motor braking current(A)	60	90	150	300
UPS type	RM120/30X	RM180/30X	RM300/30X	RM600/30X
RM/BAU	RM/BAU200			2xRM/BAU200
Max feedback energy that can be absorbed	80kW	120kW	200kW	2x120kW

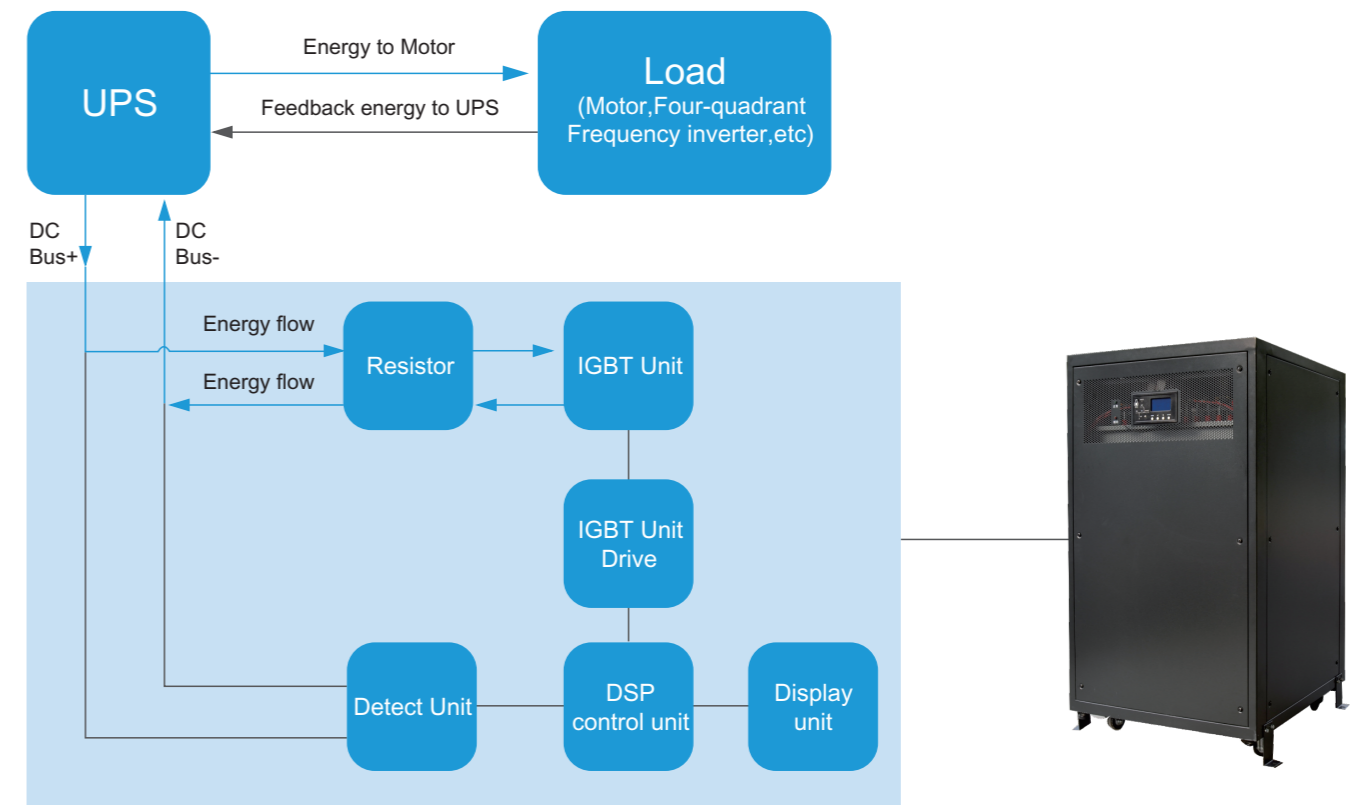

24A External Charger

24A External Charger is designed for large current charging application where long back up time is required. It applies to HT1106XL, HT1110XL and HTX31 series UPS.

It is the same appearance and size as HT1106XL. The charging current range is from 1A to 24A, and it can be set on LCD.

This Charger includes several communication ports: RS232, EPO, USB.

Solution



Load Bus Synchronization

Load Bus Synchronization (LBS) is designed to improve the redundancy and reliability for N+1 redundant system. In normal situation, UPS1 and UPS2 work equally with its own load, when one UPS goes failure, the system transfer to another UPS without interruption. And the LBS is used to synchronize the output phase of two UPS.

LBS is applied in three mode: LBS mode, parallel LBS mode and slave LBS mode.

Solution

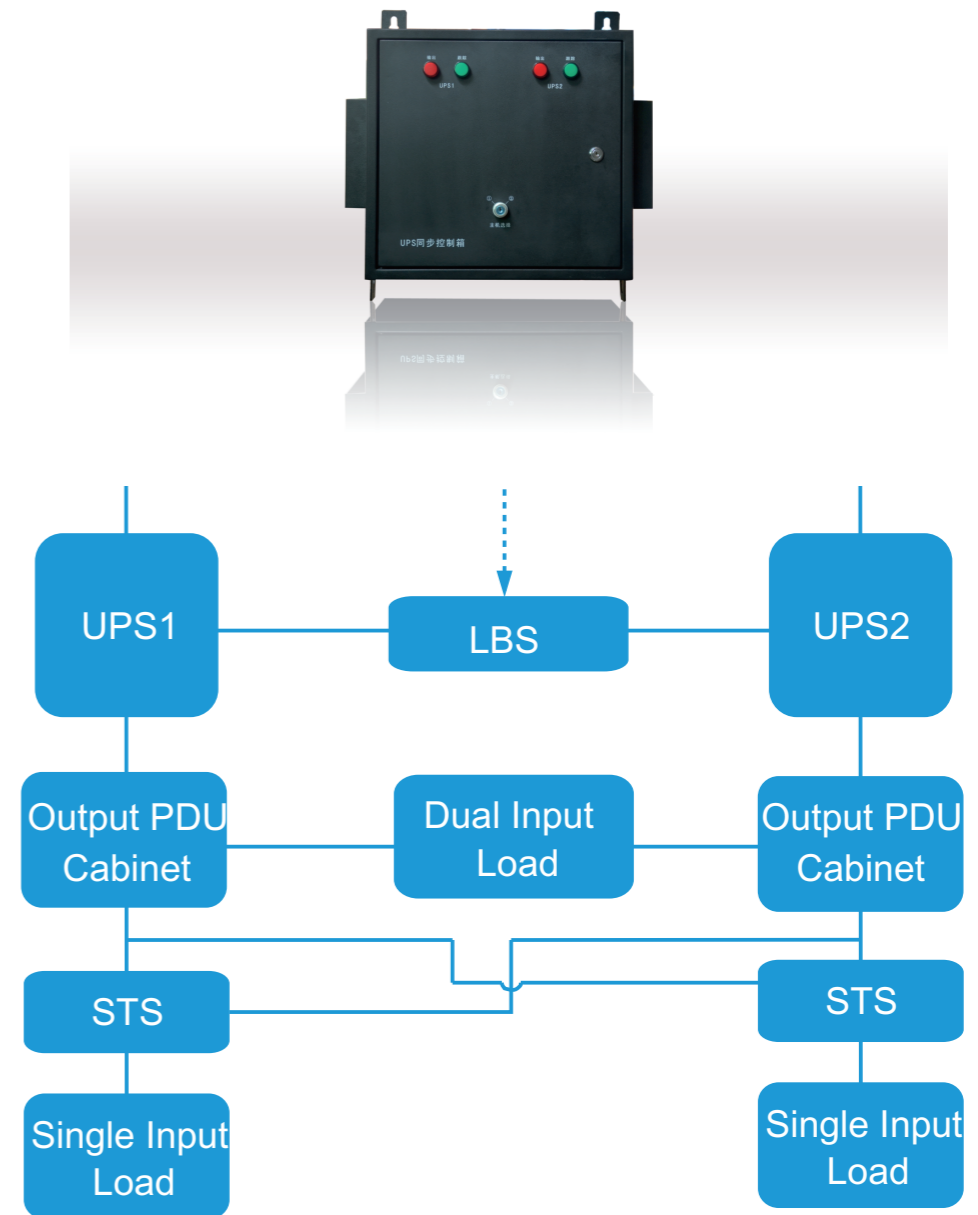

Battery Cabinet

The battery cabinet is made of cold rolled steel or galvanization plates of high mechanical performance and bearing capacity. The compact structure with electrostatic spraying makes the cabinet more wear-resistant, corrosion-resistant and fireproofing.

The cabinet is designed as assembly type which is convenient for transportation. All these guarantee the reliability and safety for the UPS.



Specification

Model	Colour	Materials	Weight	Layer	Size(mm)	QTY of Battery
C1A	Computer grey and black	Steel plates or galvanized plates	4.5kg	1	525*210*225	17AH, 6PCS;24AH, 4PCS; 38AH 3PCS;
C3	Computer grey or black	Steel plates or galvanized plates	9kg	1	585*470*335	17AH,14PCS;24AH,6PCS; 38AH ,6PCS; 65AH, 3PCS; 100AH 3PCS;
C6	Computer grey or black	Steel plates or galvanized plates	16kg	2	585*470*615	17AH ,28PCS;24AH, 12PCS; 38AH, 12PCS; 65AH, 6PCS; 100AH 6PCS;
C8	Computer grey or black	Steel plates or galvanized plates	21kg	2	780*470*615	17AH 36PCS;24AH, 16PCS; 38AH, 16PCS;65AH ,8PCS; 100AH, 8PCS;
C12	Computer grey or black	Battery terminal	32kg	4	780*470*910	24AH,24PCS;38AH,24PCS 65AH,12PCS;100AH,12PCS;
C16	Computer grey or black	Steel plates or galvanized plates	44kg	4	780*470*1190	24AH,32PCS;38AH,32PCS; 65AH,16PCS;100AH,16PCS;
C20	Computer grey or black	Steel plates or galvanized plates	50kg	4	950*470*1190	24AH,40PCS;38AH,40PCS; 65AH,20PCS;100AH,20PCS;
C40-100	Computer grey or black	Steel plates or galvanized plates	95kg	4*2	950*880*1190	65AH,40PCS; 100AH,40PCS;
C40-120	Computer grey or black	Steel plates or galvanized plates	120kg	4*2	1000*880*1475	120AH,40PCS;
G40-150	Computer grey or black	Steel plates or galvanized plates	150kg	4*2	1100*1170*1480	150AH,40PCS;
G40-200	Computer grey or black	Steel plates or galvanized plates	200kg	3*2	1900*1270*1260	200AH,40PCS;

MF Series Sealed Lead Acid Battery

2V/6V/12V (4AH-3000AH)

- Long life expectancy
- Maintenance free
- Low self discharging
- High reliability



Specification

Model	RatedVoltage(V)	Capacity(Ah)	Dimension(±1mm)				Weight±5% kg
			Length mm	Width mm	Height mm	Total Height mm	
MF4-12	12	4	91	71	102	108	1.4
MF7-12	12	7	151	65	94	100	2.15
MF9-12	12	9	151	65	96	100	2.5
MF12-12	12	12	151	98	95	101	3.4
MF17-12	12	17	181	77	167	171	5.2
MF24-12	12	24	166	175	125	129	7.6
MF38-12	12	38	197	165	170	170	12.4
MF65-12	12	65	350	167	179	179	19.6
MF100-12	12	100	328	171	214	220	30.5
MF120-12	12	120	410	176	227	227	33.5
MF150-12	12	150	482	170	242	242	44.5
MF200-12	12	200	522	238	218	222	60
MF250-12	12	250	520	269	220	224	69.5
MF4-6	6	4	70	47	101	107	0.65
MF7-6	6	7	151	34	94	100	1.08
MF9-6	6	9	98	56	117	117	1.35
MF12-6	6	12	151	50	94	100	1.7
MF100-6	6	100	195	170	207	213	16.5
MF150-6	6	150	260	180	247	251	23.5
MF200-6	6	200	250	125	362	366	31
MF300-6	6	300	295	178	345	350	47
MF100-2	2	100	171	72	206	211	6.3
MF150-2	2	150	172	102	205	227	8.1
MF200-2	2	200	177	88	371	377	13.5
MF300-2	2	300	177	118	371	377	18.5
MF400-2	2	400	177	148	371	377	24
MF500-2	2	500	177	187	371	377	30
MF600-2	2	600	218	178	371	377	36
MF800-2	2	800	290	180	371	378	48
MF1000-2	2	1000	368	180	371	378	59
MF1500-2	2	1500	590	189	380	385	89
MF2000-2	2	2000	361	412	380	385	119
MF3000-2	2	3000	590	361	380	385	179